

# DYNAMIC BANDWIDTH ALLOCATION WITH FAIR SCHEDULING FOR WCDMA SYSTEMS

LIANG XU, XUEMIN SHEN, AND JON W. MARK  
UNIVERSITY OF WATERLOO

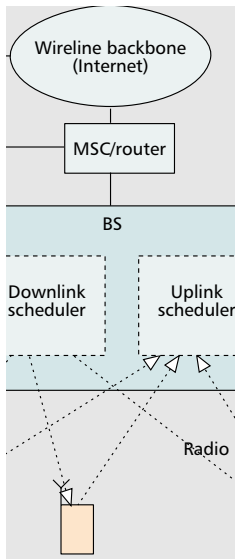

Dynamic bandwidth allocation will play an important role in future broadband wireless networks, including the third- and fourth-generation wideband code-division multiple access systems.

## ABSTRACT

Dynamic bandwidth allocation (DBA) will play an important role in future broadband wireless networks, including the 3G and 4G WCDMA systems. A code-division generalized processor sharing (CDGPS) fair scheduling DBA scheme is proposed for WCDMA systems. The scheme exploits the capability of the WCDMA physical layer, reduces the computational complexity in the link layer, and allows channel rates to be dynamically and fairly scheduled in response to the variation of traffic rates. Deterministic delay bounds for heterogeneous packet traffic are derived. Simulation results show that the proposed CDGPS scheme is effective in supporting differentiated QoS, while achieving efficient utilization of radio resources.

## INTRODUCTION

Future wireless networks are expected to support IP-based multimedia traffic with diverse quality of service (QoS) requirements. One of the promising approaches to support differentiated QoS is to employ a central controller that can dynamically allocate bandwidth to mobile users according to the variation of channel condition and traffic load. Such a dynamic bandwidth allocation (DBA) scheme should be efficient in utilizing radio resources, and fair in scheduling services. By efficiency, we mean that a user can get as much service as needed whenever there are idle resources available in the networks. By fairness, we mean that each user can be guaranteed the agreed-on service rate, even though other users are greedy in demanding bandwidth. Fair scheduling schemes have been studied for packet networks where heterogeneous traffic flows may share the same link [1, 2]. One of the idealized fair scheduling disciplines is called generalized processor sharing (GPS) [1]. It is evident that a fair distribution of link capacity to heterogeneous traffic flows according to the GPS discipline will not only guarantee QoS to each individual user, but also benefit the overall utilization of network resources. However, conventional implementation of GPS is based on a time scheduling approach

which may only be suitable for time-division multiple access (TDMA)-based wireless networks [3-4], and cannot simply be adopted for code-division multiple access (CDMA) systems without significantly increasing system complexity [5].

Wideband CDMA (WCDMA) has been proposed as a key air interface technique for third-generation (3G) wireless systems, and will likely continue to be adopted as a candidate for 4G systems that will provide differentiated service to multimedia IP traffic [6]. With the capability of dynamically varying user channel rates, WCDMA systems can provide more flexibility in bandwidth allocation. Although the idea of DBA by varying channel rate in WCDMA systems was recently adopted for supporting multiple QoS [7-8], the fair scheduling issue has not been well addressed. In this article a code-division generalized processor sharing (CDGPS) fair scheduling scheme is proposed that employs both DBA and the GPS discipline to provide fair services in a WCDMA system. The CDGPS scheduler makes use of both the traffic characteristics in the link layer and the adaptivity of the WCDMA physical layer to achieve efficient utilization of radio resources. It adjusts only the channel rate (service rate) of each traffic flow in the WCDMA system by varying the spreading factor and/or using a multiple of orthogonal code channels, rather than allocating service time to each packet. This results in lower implementation complexity of the CDGPS scheme than for a conventional GPS-based time scheduling scheme, while the performance is comparable to that of the ideal GPS in terms of bounded delay and guaranteed bandwidth provision.

The rest of this article is organized as follows. The system model is briefly described in the following section. The principle of dynamic bandwidth allocation with fair scheduling is discussed. We then describe the proposed CDGPS scheme in detail. Performance of the proposed scheme is demonstrated by simulation results, followed by concluding remarks.

## THE SYSTEM MODEL

We consider a frequency-division duplex (FDD) WCDMA cellular network where mobile stations (MSs) are interconnected with the wireline

Internet backbone network through base stations (BSs) and mobile switching centers (MSCs), as shown in Fig. 1. The wireless link in the FDD WCDMA system is characterized by orthogonal channels in the downlink (from BS to MS) and multiple access channels in the uplink (from MS to BS). A pair of bandwidth schedulers are assumed to reside in each BS. The schedulers allocate the power and rate of the channels in the uplink and downlink, respectively, to all mobile users in the same cell covered by the BS. In this article our discussion focuses on the uplink, while similar approaches can be applied to the downlink.

The physical data channels in the uplink comprises a small number of random access channels and a large number of dedicated channels. Each mobile user is assigned to at least one dedicated data channel, and shares the random access channels with other users in the same cell. While signaling and short messages may be transmitted freely via the random channels, most IP data flows are scheduled for transmission on the dedicated channels. The rate of each dedicated channel can be changed dynamically, by varying the spreading factor and/or using multicode CDMA (MC-CDMA) [9]. However, the total uplink capacity, in terms of the sum of all the uplink channel rates, is limited by intracell and intercell multiple access interference (MAI), and varies as the interference varies. It is assumed that the total capacity of the rate-variable dedicated channels is known by the scheduler since the interference level can be measured and estimated at the BS. The total capacity of these dedicated channels is considered the uplink radio resource shared by the mobile users in the same cell.

Multimedia IP traffic (e.g., voice, video, and data) is considered. QoS requirements of IP traffic generally consist of two parts: delay and loss rate. In order to guarantee the QoS for all users, each traffic source is shaped by a leaky bucket regulator [10] with parameter  $(\sigma, \rho)$ , where  $\sigma$  and  $\rho$  are token buffer size and token generating rate, respectively, of the leaky bucket. In this article we use the  $(\sigma, \rho)$  model to characterize IP traffic source in the uplink system.

## DYNAMIC BANDWIDTH ALLOCATION GPS FAIR SCHEDULING DISCIPLINE

The DBA scheduler is the core of the link-layer control entity, which in general:

- Supports differentiated QoS for IP traffic
- Makes efficient use of physical layer resources, by taking into account the variation of channel conditions as well as the traffic load

In WCDMA-based cellular networks, both the channel rate and transmission power of each user should be dynamically adjusted, such that the user QoS requirements can be guaranteed with high utilization of the radio resource. While dynamic rate allocation aims to satisfy the delay requirement, dynamic power assignment (power control) is applied to compensate for channel impairment and to maintain a satisfactory loss rate. In practical systems, the signal-to-interference-ratio (SIR)-based power control mecha-

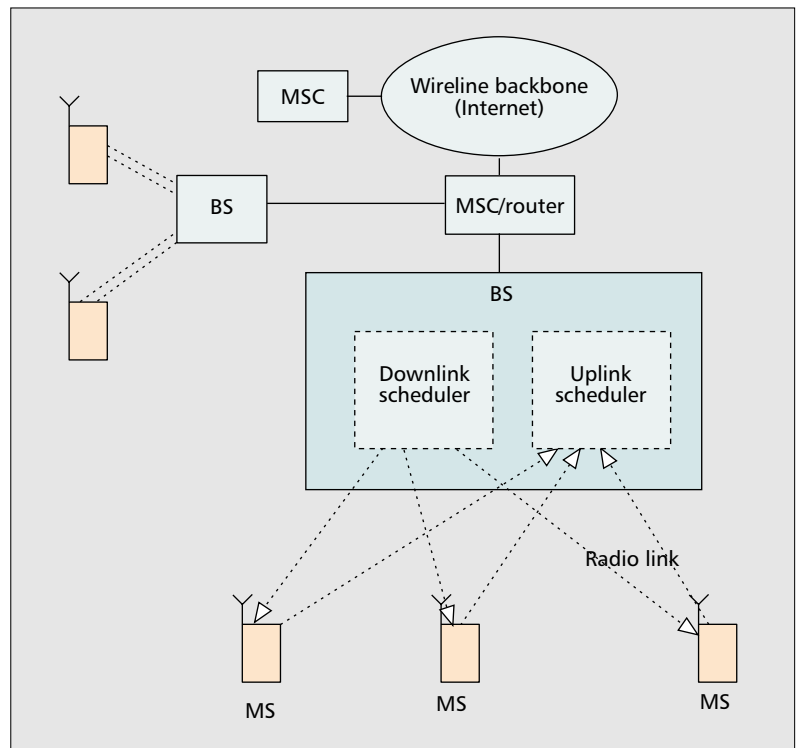
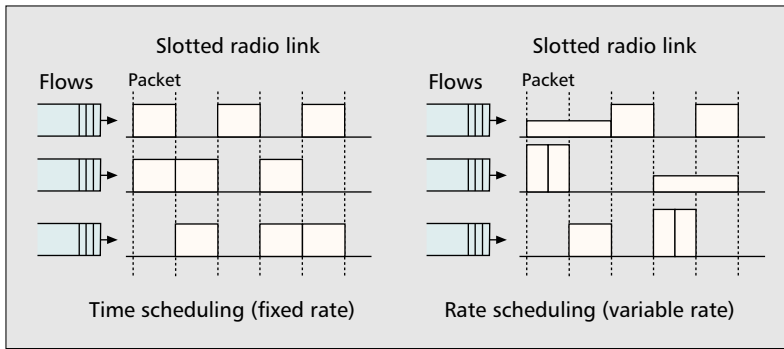

Figure 1. The network structure.

nism, which maintains a target SIR at the receiver side of each dedicated uplink channel, can be applied to guarantee the loss rate requirement. As a result, the DBA scheduler can only be concerned with the delay due to the variation of traffic. If the instantaneous arriving rate of a traffic flow exceeds its allocated bandwidth, packet delay becomes significant. Conversely, if a traffic flow is allocated more bandwidth than it actually uses, the overall system utilization drops. Furthermore, the overall system bandwidth should be distributed to users in a fair manner according to a fair scheduling discipline so that each user is guaranteed its required bandwidth, and greedy users cannot affect the QoS performance of well-behaved users. Thus, the overall goal of the DBA is to effectively and efficiently perform fair scheduling for traffic flows in WCDMA networks.

GPS [1] is an ideal fair scheduling discipline that has attracted much attention to its application in both wireline [2] and wireless packet networks [3–5]. A basic principle of GPS is to assign a fixed positive real number (namely weight), instead of a fixed bandwidth, to each flow, and to dynamically allocate bandwidth for all flows according to their weights and traffic load. Consider  $N$  packet flows sharing a network link with total bandwidth  $C$ . Let the weight for flow  $i$  be  $\phi_i$ . Let  $S_i(\tau, t)$  denote the amount of flow  $i$  traffic served during an interval  $(\tau, t]$ . Then a GPS server is defined as one for which the following inequality holds for any flow  $i$  that is continuously backlogged in any interval  $(\tau, t]$  [1]:

$$\frac{S_i(\tau, t)}{S_j(\tau, t)} \geq \frac{\phi_i}{\phi_j}, j = 1, 2, \dots, N \quad (1)$$



■ **Figure 2.** Rate scheduling and time scheduling.

If all the flows are continuously served by the GPS server during interval  $(\tau, t]$ , then Eq. (1) holds with equalities, and the allocated bandwidth of each user is exactly proportional to its weight. Due to the burstiness of packet traffic, sometimes a user may not have packets to transmit and gives up its bandwidth for a while. The excess bandwidth can be distributed among all backlogged sessions at each instant in proportion to their individual weight  $\phi_i$ . This makes the GPS server efficient and fair in bandwidth allocation. Furthermore, it has been proven [1] that a tight delay bound can be guaranteed by the GPS server if a traffic flow is shaped by the leaky bucket regulator. Given that shaped flow  $i$  is modeled by  $(\sigma_i, \rho_i)$  and the guaranteed rate  $g_i \geq \rho_i$ , the delay bound is  $\sigma_i/\rho_i$ . With the bounded delay guarantee, the GPS server can effectively support user QoS requirements. It should be mentioned that the ideal GPS server requires Eq. 1 to be held at any time interval, which is not realizable in practical systems. In the time-division multiplexed link, for instance, only one packet can be transmitted at a time; hence, Eq. 1 cannot hold in a small timescale. In practice,

the well-known packet-by-packet GPS (PGPS) time scheduling scheme [1], also known as Weighted Fair Queueing (WFQ), can only approximately satisfy Eq. 1 over a long interval relative to packet transmission time and provide a larger delay bound than that of the ideal GPS. Nevertheless, the ideal GPS server can be found useful to serve as a hypothetical reference system to facilitate the implementation of the PGPS scheme.

There are two approaches to realize DBA with the GPS discipline in WCDMA systems: time scheduling and rate scheduling. Figure 2 illustrates the difference between the two. Let three packet flows share the WCDMA uplink. In order to facilitate the DBA, the uplink is divided into time slots, and the scheduling is performed slot by slot. With time scheduling, the channel rate of each user is usually fixed, and the DBA scheduler arranges the service time of each packet. With rate scheduling, in contrast, the DBA scheduler arranges the channel rate of each user for each slot, and different packets in the same flow may be transmitted at different rates. The time scheduling approach was adopted in [5] to realize GPS in a hybrid CDMA/TDMA system, which is an extension of the PGPS scheme. With the PGPS scheme, a hypothetical GPS server needs to be simulated for calculating a virtual service time for each packet. Based on the simulated virtual time, packets from different flows are sequenced and arranged for transmission. However, this packet-by-packet time scheduling approach induces excessive computational complexity and signaling overhead for CDMA systems, which makes it difficult to be implemented. In the following section, a dynamic rate scheduling approach is proposed, which is aimed at making use of the physical layer capability of the WCDMA system to reduce the implementation complexity of GPS.

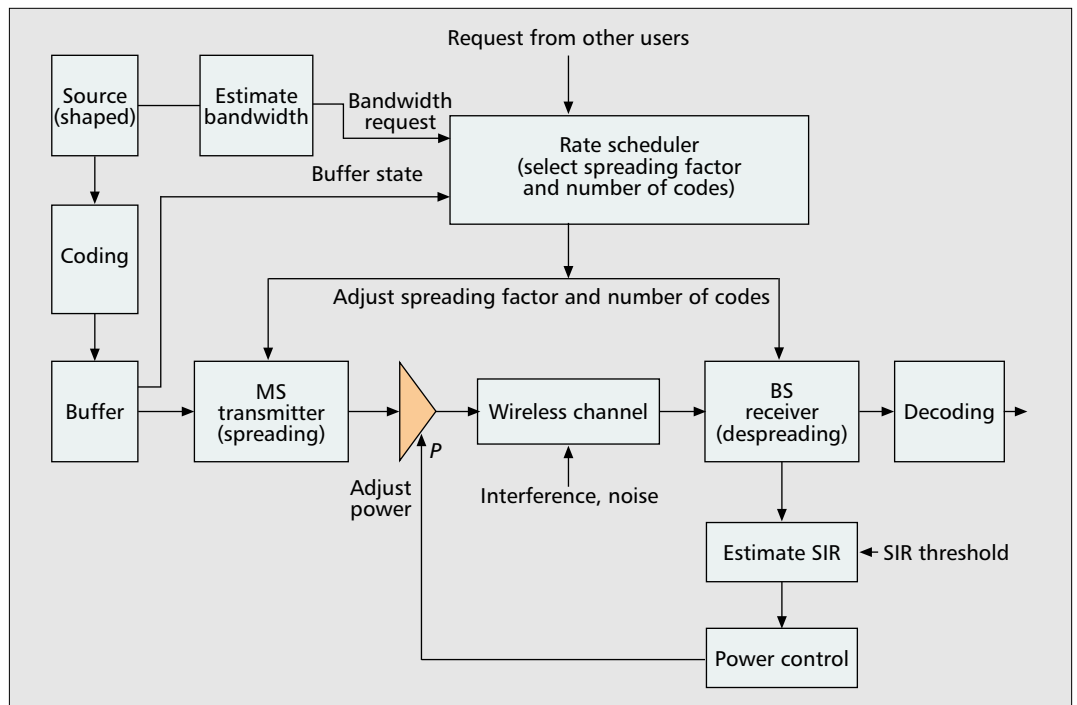

■ **Figure 3.** A rate-scheduled WCDMA system.

## THE CODE-DIVISION GPS FAIR SCHEDULING SCHEME

The proposed CDGPS scheme uses the GPS fair scheduling discipline to dynamically allocate channel rates. The scheme is developed based on a rate-scheduled WCDMA system, as shown in Fig. 3. The source of each MS generates a sequence of packets that enter a buffer after error control coding. The buffered information bits are then converted to a direct-sequence CDMA (DS-CDMA) signal with symbol rate  $R_c/N_s$ , where  $R_c$  is the chip rate and  $N_s$  the spreading factor. Since the chip rate (spread bandwidth) is fixed, the spreading factor  $N_s$  (number of chips per symbol) determines the service rate (or channel rate) at which the buffer is emptied. If MC-CDMA is employed (i.e., more than one spreading code can be used by one user), the service rate can be  $mR_c/N_s$ , where  $m$  is the number of code channels.

The channel rate of each MS is scheduled slot by slot. By the end of each time slot, the MS sends a short message through the random access channel or its own dedicated channel to the BS, reporting buffer state and the amount of traffic that arrived in the previous slot. Upon receiving bandwidth requests from all active users, the scheduler allocates the channel rate for the next slot, taking into account user QoS requirements and the available uplink capacity. The resource allocation message, in terms of the spreading factor and the number of codes of each user, will be sent via downlink channels before the start of the next slot. Upon receiving a resource allocation message indicating that the rate needs to be changed, the MS immediately adjusts its spreading factor and/or number of codes at the start of the next slot. In order to maximize the utilization of uplink capacity, the rates of different channels are changed simultaneously, and all the uplink channels are synchronized at the slot level. This, however, does not require strict bit synchronization among different channels, and can be supported by asynchronous WCDMA systems. SIR-based fast power control is performed to guarantee a target bit error rate (BER) at the output of the receiver at the BS by adapting the transmission power of the MS in response to variations of MAI and channel fading. When the channel rate is changed, the SIR threshold is adjusted accordingly so that the target BER can be maintained.

Figure 4 shows the queuing model of the proposed CDGPS scheme, where total link capacity  $C$  is shared by  $N$  flows. Each flow maintains a connection with link rate  $C_i(k)$  during the  $k$ th time slot. The sum of  $C_i(k)$  over all users should not exceed  $C$ . From the viewpoint of any flow  $i$ , it is entering a single-server queuing system with service rate  $C_i(k)$ . Different from a conventional single-server queue, the service rate  $C_i(k)$  may vary periodically. For each slot, the scheduler allocates adequate service rates to the  $N$  flows, using the following scheduling procedure.

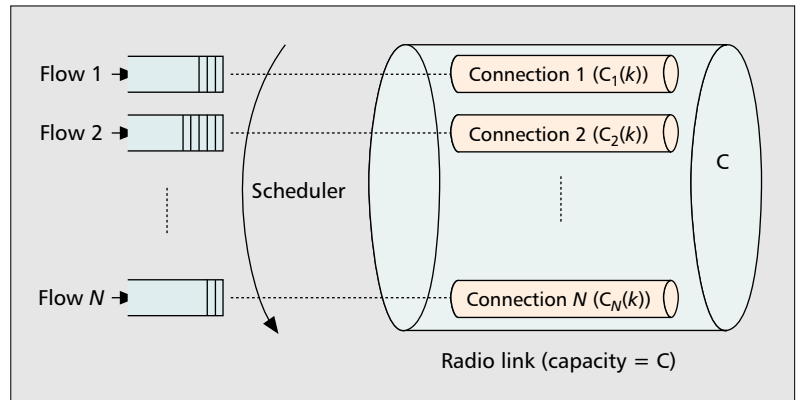

Figure 4. A queuing model of the CDGPS scheme.

### THE RATE SCHEDULING PROCEDURE

Let the pre-assigned weight for flow  $i$  be  $\phi_i$ ,  $i = 1, 2, \dots, N$ . Let  $S_i(k)$  denote the amount of session  $i$  traffic that would be served during time slot  $k$ . Then, according to the GPS scheduling discipline, Eq. (1) should hold for any flow  $i$  that is continuously backlogged in the time slot  $k$ . Let the scheduling period of the CDGPS scheme, that is, the slot length, be  $T$ . The proposed CDGPS server allocates each  $C_i(k)$  using the following steps:

Step 1. Let  $B_i(k)$  be the total amount of backlogged traffic of flow  $i$  during time slot  $k$ . Estimate  $B_i(k)$ ,  $i = 1, 2, \dots, N$ , as follows:

$$B_i(k) = Q_i(\tau_k) + r_i(k)T, \quad (2)$$

where  $\tau_k$  is the end time of slot  $k - 1$ , and  $Q_i(\tau_k)$  is the backlogged traffic at time  $\tau_k$ ;  $r_i(k)$  is the estimated traffic arrival rate of flow  $i$  during time slot  $k$  and can be estimated from past traffic measurement. The following two approaches to rate estimation can be used:

- One-step estimation: Let  $r_i(k) = a_i(k - 1)/T$ , where  $a_i(k - 1)$  is the total amount of the arrival traffic (in bits) during time slot  $k - 1$ .
- Exponential averaging: Let  $t_i^n$  and  $l_i^n$  be the arrival time and length of the  $n$ th packet of flow  $i$ , respectively. The estimated rate of flow  $i$ ,  $r_i$ , is updated every time a new packet arrives:

$$r_i^{new} = (1 - e^{-T_i^n/K}) \frac{l_i^n}{T_i^n} + e^{-T_i^n/K} r_i^{old}, \quad (3)$$

where  $T_i^n = t_i^n - t_i^{n-1}$  and  $K$  is a constant.

Step 2. Based on the estimated  $B_i(k)$ ,  $i = 1, 2, \dots, N$ , determine each  $S_i(k)$  which is the expected amount of service received by the  $i$ th user.

- If  $B_i(k) = 0$ , then  $S_i(k) = 0$ .
- If  $B_i(k) > 0$ , then  $S_i(k) = g_i T$ , where

$$g_i = \frac{\phi_i C}{\sum_{j=1}^N \phi_j} \quad (4)$$

is the minimum rate guaranteed to user  $i$ .

- If  $\sum_i S_i(k) < CT$ , where  $C$  is the maximal amount of service rate that can be provided by the network, the remaining network resource is distributed to users who expect more than their guaranteed service  $g_i T$ . The distribution of the remaining network resources should be

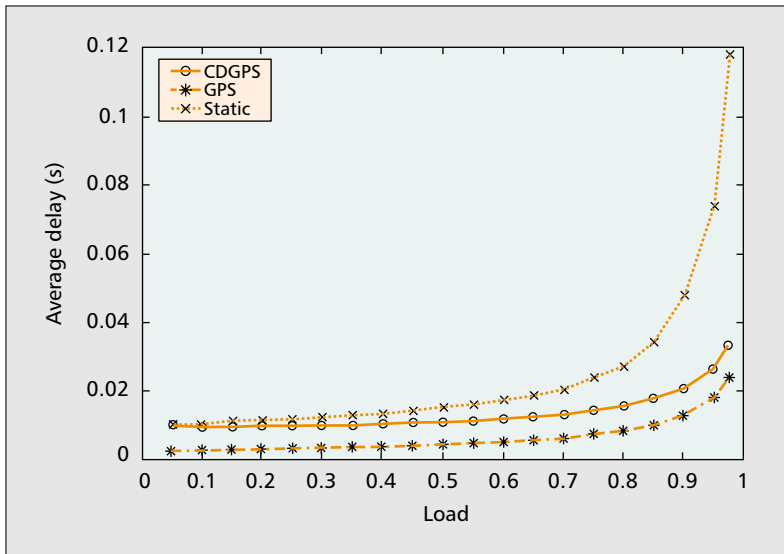

■ Figure 5. Average delay comparison.

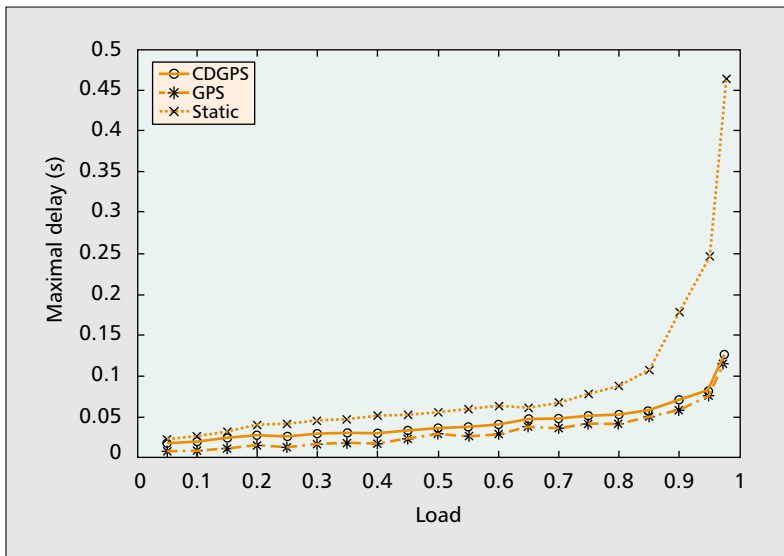

■ Figure 6. Maximal delay comparison.

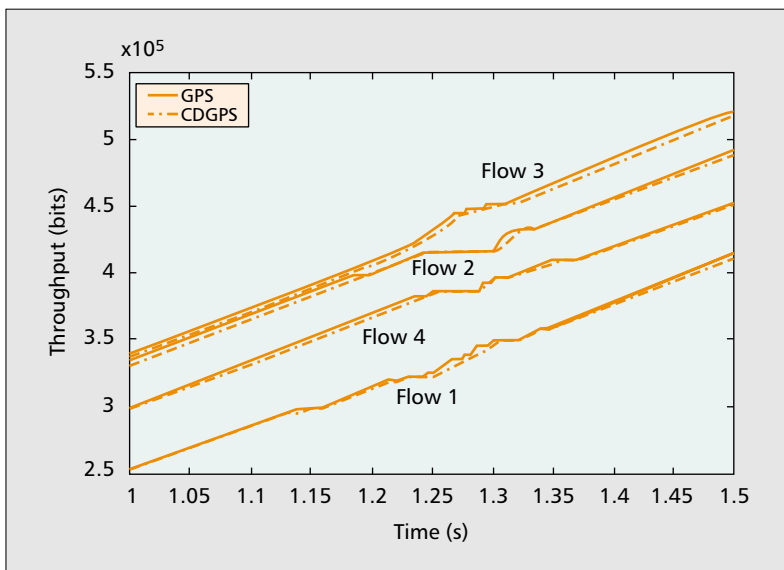

■ Figure 7. Throughput comparison of CDGPS and GPS (same weights).

in proportion to each user's weight  $\phi_i$  according to the GPS service discipline.

Step 3. The allocated channel rate to user  $i$  can be determined by  $C_i(k) = S_i(k)/T$ .

### DELAY BOUND

Let traffic flow  $i$  be regulated by a leaky bucket with token buffer size  $\sigma_i$  and token generating rate  $\rho_i$ . Let  $Q_i^*$  be the maximum flow  $i$  backlog (i.e., the maximum of  $Q_i(t)$ ). The delay bound for the traffic flow  $i$  can be derived with the following lemma:

*Lemma 1:* If  $g_i \geq \rho_i$ , where  $g_i$  is given by Eq. (4), then the maximum backlog  $Q_i^* \leq \sigma_i + \rho_i T$ .

With lemma 1, the following delay bound for flow  $i$  can be obtained.

*Theorem 1:* If  $g_i \geq \rho_i$ , then the packet delay of flow  $i$  is bounded by

$$\text{Delay}_{\max} \leq \frac{\sigma_i}{g_i} + T. \quad (5)$$

### FAIRNESS

Similar to the ideal GPS server, a CDGPS scheduler ensures weighted fairness to heterogeneous traffic. The CDGPS server can guarantee each backlogged flow with at least the minimum rate  $g_i$  which is proportional to its weight  $\phi_i$ . In addition, the excess bandwidth available from flows not using their reserved rates is distributed among all of the backlogged flows in each time slot in proportion to their individual weights. This results in short-term fairness during a slot period  $T$ . The long-term fairness property of the CDGPS scheme can be explained by comparing the delay bound of Eq. (5) with the ideal GPS delay bound  $\sigma_i/g_i$  given in [1]. It can be seen that the difference between the two bounds is no more than  $T$ , which implies that in the long term the services provided to user  $i$  by CDGPS are equivalent to those provided by the GPS. This explains the fact that the CDGPS ensures weighted fairness, as does the ideal GPS.

The weighted fairness feature of the proposed CDGPS scheme is important for providing differentiated services in WCDMA networks, since different traffic flows can be isolated while sharing the same radio resource.

### SIMULATION

In this section we present simulation results to demonstrate the delay performance, fairness feature, and system utilization of the proposed CDGPS scheme. In the simulation, WCDMA uplink channels with a total capacity  $C = 2$  Mb/s are used. Perfect power control on the WCDMA uplink and error-free channels are assumed. The simulated WCDMA system can support three classes of packetized traffic: voice, video, and best effort data. A one-step traffic rate estimation approach is adopted in the CDGPS rate scheduling procedure. The scheduling period  $T$  is 10 ms.

We first simulate four homogeneous best effort packet data flows. Each of these flows is modeled by a Poisson process with average arriving rate  $\lambda$  and packet length  $L$ , shaped by a leaky bucket regulator with  $\sigma = 20L$  and  $\rho = C/4$ . In

the simulation,  $L = 5120$  bits.  $\lambda$  can be varied in order to change the system load. A hypothetical GPS scheduler with service rate  $C = 2$  Mb/s is simulated, providing a performance benchmark. We also simulate a static rate allocation scheme compared to our proposed dynamic rate scheduling scheme. Unlike the CDGPS scheme, the static rate allocation scheme will assign a fixed channel rate equal to the guaranteed rate  $g_i$  in the CDGPS scheme to each packet flow. Figures 5 and 6 show average delay and maximal delay, respectively, with different system load. In the figures the system load is normalized to be  $\text{Load} = 4 * \lambda / C$ . We vary the packet arriving rate  $\lambda$  of each flow to change the system load. From Figs. 5 and 6 it can be seen that the delay performance of CDGPS is close to that of GPS, and better than that of the static scheme. As expected, the idealized GPS can achieve lower average and maximal delay. This is because the GPS is supposed to perform, hypothetically, bit-by-bit scheduling that can instantly respond to traffic variation. The difference between the delay performance of CDGPS and GPS is mainly due to the scheduling period  $T$  and does not significantly change with load. The maximal delay with CDGPS is less than a theoretical delay bound computed from Eq. (5), which is 0.21 s in this simulation. The CDGPS is superior to the conventional static rate allocation scheme with respect to delay performance. As shown in Fig. 5, the average delay with the static scheme is close to that with CDGPS when the system load is light, but grows much faster than that with CDGPS when the system load increases. As shown in Fig. 6, when the system load is light, the maximal delay with CDGPS is less than that with the static scheme, and far below the theoretical delay bound. The theoretical delay bound of CDGPS is only reached when the system load approaches 1. This is because CDGPS is more flexible in allocating bandwidth and can make

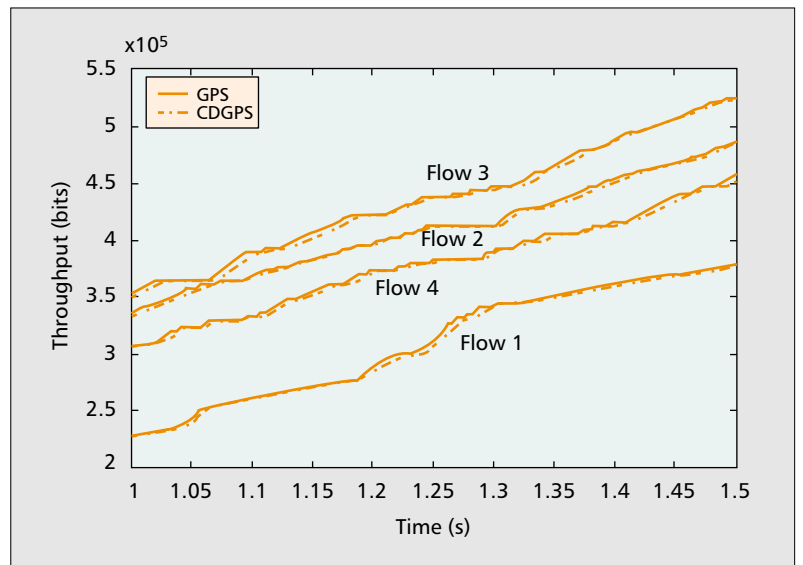

■ Figure 8. Throughput comparison of CDGPS and GPS (different weights).

use of idle network resources to improve delay performance when the system load is light.

Figures 7 and 8 give the throughput comparison of CDGPS and GPS. Figure 7 shows four flows assigned to the same weights ( $\phi_1 = \phi_2 = \phi_3 = \phi_4$ ), while Fig. 8 shows them given different weights ( $\phi_1 = \phi_2/2 = \phi_3/3 = \phi_4/4$ ) (i.e., different priorities). It can be seen that both CDGPS and GPS schedulers can fairly allocate service rates to different flows, according to their assigned weights, and the throughput using the CDGPS scheduler is very close to that of the ideal GPS scheduler, which demonstrates the weighted fairness property of CDGPS.

To demonstrate the performance of CDGPS in a heterogeneous traffic environment, 10 voice flows, three VBR video flows, and four best

Flow ID	Traffic type	Throughput (packets)	Average delay (s)	Max. delay (s)	Delay bound (s)
Flow 1	Voice	3019	0.003850	0.011976	0.01258
Flow 2		2253	0.004035	0.011875	0.01258
Flow 3		1844	0.004375	0.010512	0.01258
Flow 4		2425	0.004107	0.009738	0.01258
Flow 5		3492	0.004246	0.012416	0.01258
Flow 6		2798	0.004013	0.011944	0.01258
Flow 7		2401	0.004260	0.012049	0.01258
Flow 8		2360	0.004007	0.011951	0.01258
Flow 9		2509	0.004772	0.012424	0.01258
Flow 10		1530	0.004052	0.011853	0.01258
Flow 11	Video	24017	0.002916	0.012382	0.01996
Flow 12		24182	0.002814	0.011012	0.01996
Flow 13		23792	0.002864	0.010598	0.01996
Flow 14	Data	2917	2.1883	3.8571	N/A
Flow 15		3025	2.7816	4.7348	N/A
Flow 16		3034	2.8141	4.7192	N/A
Flow 17		3021	2.2572	4.3340	N/A
Utilization			0.951		

■ Table 1. Delay performance for heterogeneous traffic.

The analysis and simulation results show that bounded delay can be provisioned for real-time application by using GPS service discipline, while high utilization of system resources is achieved. The dynamic rate scheduling approach used by the proposed CDGPS scheme improves the delay performance over the conventional static scheme.

effort data flows are simulated. Voice traffic is generated using an on-off model. In the on state, the voice packets arrive at a constant rate  $R_{vo} = 16 \text{ kb/s} = 200 \text{ packets/s}$ , where the packet length  $L_{vo}$  is 80 bits. The voice activity factor is assumed to be 0.4. VBR video traffic is generated by using an 8-state MMPP model. In each state, packet arrival is assumed to be a Poisson process. The average duration in each state is chosen to be 40 ms, which is equivalent to the length of one frame of the video sequence with a frame rate of 25 frames/s. A Poisson process is used to generate the best effort data traffic with packet size 2560 bits and average arrival rate 256 kb/s. Simulation results are summarized in Table 1, where the average and maximal delay of each flow are compared to the analytical delay bound obtained from Eq. (5). Network resource (bandwidth) utilization is also calculated. It can be seen that low average packet delays are achieved by the real-time traffic flows, voice and video, under the proposed CDGPS scheduling scheme. The maximal packet delays are less than the theoretical bounds. Table 1 also shows that the proposed scheduling scheme gives a high utilization of the total uplink capacity.

## CONCLUSION

We have proposed an efficient dynamic fair scheduling scheme to support QoS in WCDMA multimedia packet networks. The analysis and simulation results show that bounded delay can be provisioned for real-time application by using GPS service discipline, while high utilization of system resources is achieved. The dynamic rate scheduling approach used by the proposed CDGPS scheme improves the delay performance over the conventional static scheme. The CDGPS scheme is simpler to implement than conventional GPS-based time scheduling schemes, and more suitable to WCDMA systems. Research to design the CDGPS fair scheduler by considering channel impairments such as fading, imperfect power control, and the fluctuation of intercell co-channel interference are underway.

## ACKNOWLEDGMENTS

A preliminary version of this work was presented at 3Gwireless 2001, San Francisco, California. The work has been supported by a grant from the Canadian Institute for Telecommunications Research (CITR), a Network of Centers of Excellence under the NCE program of the Federal Government of Canada.

## REFERENCES

- [1] A. K. Parekh and R. G. Gallager, "A Generalized Processor Sharing Approach to Flow Control in Integrated Services Networks: The Single-Node Case," *IEEE Trans. Net.*, vol. 1, June 1993, pp. 344–57.
- [2] D. Stiliadis and A. Varma, "Efficient Fair Queueing Algorithms for Packet-Switched Networks," *IEEE/ACM Trans. Net.*, vol. 6, Apr. 1998, pp. 175–85.
- [3] P. Ramanathan and P. Agrawal, "Adapting Packet Fair Queueing Algorithms to Wireless Networks," *Proc. ACM/IEEE MOBICOM'98*, Dallas, TX, Oct. 1998, pp. 1–9.

- [4] S. Lu, V. Bhargavan, and R. Srikant, "Fair Scheduling in Wireless Packet Networks," *IEEE/ACM Trans. Net.*, vol. 7, Aug. 1999, pp. 473–89.
- [5] M. A. Arad and A. Leon-Garcia, "A Generalized Processor Sharing Approach to Time Scheduling in Hybrid CDMA/TDMA," *Proc. IEEE INFOCOM '98*, San Francisco, CA, Mar. 1998, pp. 1164–71.
- [6] W. W. Lu, "Compact Multidimensional Broadband Wireless: The Convergence of Wireless Mobile and Access," *IEEE Commun. Mag.*, Nov. 2000, pp. 119–23.
- [7] S.-J. Oh and K. M. Wasserman, "Dynamic Spreading Gain Control in Multiservice CDMA Networks," *IEEE JSAC*, vol. 17, May 1999, pp. 918–27.
- [8] O. Gurbuz and H. Owen, "Dynamic Resource Scheduling for Variable QoS Traffic in W-CDMA," *Proc. IEEE ICC '99*, 1999.
- [9] H. Holma and A. Toskala, *WCDMA For UMTS: Radio Access For Third Generation Mobile Communications*, John Wiley Inc., 2000.
- [10] M. Schwartz, *Broadband Integrated Networks*, Prentice Hall, 1996.

## BIOGRAPHIES

LIANG XU received a B.S. degree from Tsinghua University, China, in 1994 and an M.Sc. degree from Southeast University, China, in 1997, both in electrical engineering. He is currently working toward a Ph.D. degree in the Department of Electrical and Computer Engineering at the University of Waterloo, Canada. His research interests include dynamic bandwidth allocation, traffic scheduling, and QoS provision in 3G and 4G wireless networks.

XUEMIN SHEN (xshen@bbr.uwaterloo.ca) received a B.Sc. degree from Dalian Marine University, China, in 1982, and M.Sc. (1987) and Ph.D. degrees (1990) from Rutgers University, New Jersey, all in electrical engineering. From September 1990 to September 1993 he was first with Howard University, Washington, D.C., and then the University of Alberta, Edmonton, Canada. Since October 1993 he has been with the Department of Electrical and Computer Engineering, University of Waterloo, where he is an associate professor. His research focuses on control algorithm development for mobility and re-source management in interconnected wireless/wireline networks. In specific, his interests are traffic flow control, connection admission and access control, handoff, user location estimation, end-to-end performance modeling and evaluation, voice over mobile IP, stochastic process and filtering. He is coauthor of the books *Singular Perturbed and Weakly Coupled Linear Systems — A Recursive Approach* (Springer-Verlag, 1990) and *Parallel Algorithms for Optimal Control of Large Scale Linear Systems* (Springer-Verlag, 1993).

JON W. MARK [F] received a B.S.Sc. degree from the University of Toronto, Ontario, Canada, in 1962, and M.Eng. and Ph.D. degrees from McMaster University, Hamilton, Ontario, Canada, in 1968 and 1970, respectively, all in electrical engineering. From 1962 to 1970 he was with Canadian Westinghouse Co. Ltd. in Hamilton, Ontario, Canada, where he was an engineer and then a senior engineer. He took leave of absence from Westinghouse in October 1968 to pursue Ph.D. studies at McMaster University under the auspices of an NRC PIER Fellowship. Since September 1970 he has been with the Department of Electrical and Computer Engineering, University of Waterloo, Waterloo, Ontario, Canada, where he is currently a professor. He was department chair from July 1984 to June 1990. He had been on sabbatical leaves at the IBM Thomas J. Watson Research Center, Yorktown Heights, New York (1976–1977) where he was a visiting research scientist, AT&T Bell Laboratories, Murray Hill, New Jersey (1982–1983) where he was a resident consultant, Laboratoire MASI, Université Pierre et Marie Curie, Paris, France (1990–1991), where he was an invited professor, and the National University of Singapore (1994–1995 and 1999) where he was a visiting professor. In 1996 he established the Center for Wireless Communications at the University of Waterloo where he is currently serving as its founding director. His current research interests are in broadband communications, wireless communications and wireless/wireline interworking.