

RESEARCH ARTICLE

Distributed power control over multiple channels for ad hoc wireless networks[†]

Khaled H. Almotairi^{1,2*} and Xuemin (Sherman) Shen¹¹ Department of Computer Engineering, Umm Al-Qura University, Makkah, Saudi Arabia² Department of Electrical and Computer Engineering, University of Waterloo, Waterloo, ON N2L 3G1, Canada

ABSTRACT

In this paper, we investigate the deficiency of uncontrolled asymmetrical transmission power over multiple channels in ad hoc environments. We further propose a novel distributed transmission power control protocol called the distributed power level (DPL) protocol for multi-channel ad hoc networks without requiring clock synchronization. Specifically, different transmission power levels are assigned to different channels, and nodes search for an idle channel on the basis of the received power so that the maximum allowable power of the preferred data channel is larger than or equal to the received power. If the most preferred channel of the least maximum power is busy, the nodes are able to select the next channel and so forth. As a result, interference is reduced over channels because the nodes that require higher transmission power are separated from interfering with the nodes that require lower transmission power. Two transmission power control modes are introduced for DPL: symmetrical and asymmetrical. For the symmetrical DPL protocol (mode), nodes transmit at the same power level assigned to the selected channel. On the other hand, for the asymmetrical DPL protocol, nodes are allowed to transmit at a lower or equal power level that is assigned to the selected channel. Extensive ns-2-based simulation results are presented to demonstrate that the proposed protocols can enhance the network throughput compared with the existing uncontrolled asymmetrical transmission power protocol. Copyright © 2012 John Wiley & Sons, Ltd.

KEYWORDS

transmission power control; power levels; symmetrical links; asymmetrical links; multi-channel networks

*Correspondence

Khaled H. Almotairi, Department of Computer Engineering, Umm Al-Qura University, Makkah, Saudi Arabia.

E-mail: khalmota@bbcr.uwaterloo.ca

1. INTRODUCTION

Because of the transmission power constraint, multi-hop ad hoc networks have recently gained significant attention because of their low-cost deployment, infrastructurelessness, and coverage extension. However, the performance of wireless ad hoc networks is limited because of interference when nodes transmit at the maximum power. Unwanted transmission power added to useful power over a channel becomes interference that not only degrades the network performance but also wastes nodes' energy, a crucial resource. Thus, transmission power is a major factor that can affect the network performance, and transmission power control (TPC) is one solution that can not only improve the spatial reuse but also reduce the interference.

For single-channel networks, a simple TPC protocol has been proposed to save energy at the medium access control (MAC) layer called *BASIC*, or *SIMPLE* [1,2]. This protocol uses the maximum power to transmit request-to-send (RTS) and clear-to-send (CTS) packets, then determines the minimum required power to transmit data and acknowledgement (ACK) packets. This approach has been proven to cause more collisions and consequently consume more energy [3–6]. For example, a source node exchanges RTS and CTS packets with a destination node using the maximum power, and the source node transmits its data packet at the minimum required power. Any node that has a packet senses the channel, but because the ongoing transmission is transmitted at a low power, the node assumes the channel is idle, and then it transmits its RTS packet at the maximum power. Thus, the node may interfere with the ongoing transmission.

Although using multiple channels with power control can increase the network performance [7], applying the

[†]Parts of this paper have been presented at IEEE Globecom 2010.

BASIC scheme over multiple channels can limit the performance. In [8], the dynamic channel assignment with power control (DCA-PC) protocol has been proposed for multi-channel networks. DCA-PC shares the same approach as BASIC; thus, the same problem that occurs in BASIC also exists in DCA-PC. In other words, DCA-PC uses uncontrolled asymmetrical transmission power over any channel.

In this paper, we study the deficiency of uncontrolled asymmetrical transmission power. Our main contributions are twofold. First, we propose a novel distributed TPC protocol called the distributed power level (DPL) protocol for multi-channel ad hoc wireless networks in order to resolve the uncontrolled asymmetrical transmission power problem. The main idea is to enhance the network throughput by efficiently using multiple channels with TPC in a distributed manner. DPL allocates different maximum allowable power values to different channels; therefore, nodes select their channels on the basis of their minimum required transmission power, so interference is reduced over channels. Second, we introduce two TPC modes for the DPL protocol: symmetrical and asymmetrical. For the symmetrical DPL protocol,[‡] nodes transmit at the power that has been assigned to the selected channel, thereby creating symmetrical links over any channel. The asymmetrical DPL protocol, on the other hand, allows nodes to transmit at a power that can be lower than or equal to the power assigned to the selected channel.

The remainder of the paper is organized as follows. Section 2 reviews the related work, and Section 3 presents the deficiency of uncontrolled asymmetric transmission power in multi-channel networks. In Section 4, we propose the novel distributed power control protocol for multi-channel ad hoc networks. Then, the performance evaluation through simulations using ns-2 is given in Section 5. Section 6 briefly presents some discussions about our proposed protocols and some practical aspects related to power assignments for different frequency ranges. Finally, we conclude our paper in Section 7.

2. RELATED WORK

Designing multi-channel MAC protocols and TPC protocols for wireless networks has been studied [6,8–23].

For single-channel networks, the TPC protocols that are similar to BASIC are proposed in [1,2]. Nodes transmit RTS and CTS packets at the highest power and then determine the minimum required transmission power to transmit data and ACK packets. In [1], the power-aware routing optimization protocol is proposed. The power-aware routing optimization is a routing protocol where the routing metric is the summation of transmission power values so that nodes select the minimum transmission power values

to save energy. As mentioned in the previous section, The BASIC scheme has been proven to increase collisions and consume more energy [4–6].

A new TPC protocol is proposed at the MAC layer called Power Control MAC [4] to resolve the asymmetrical links associated with BASIC. Unlike BASIC, Power Control MAC determines the minimum transmission power, but, during data packet transmissions, nodes periodically increase and decrease the transmission power between the maximum power and the minimum power. The main focus of this protocol is to save energy. Power-stepped protocol is proposed in [24], and it allows each nodes to operate at one of transmission power levels. The selected power level of any node must be within one level higher or lower than that of any of its neighbors.

In [22], a new TPC protocol, called POWMAC, has been proposed to create asymmetrical links in the network. The idea is similar to the BASIC scheme but is more complex. In [25], a new adaptive transmission power controlled MAC protocol, called ATPMAC, is proposed to enhance the network throughput by using a single channel and a single transceiver. ATPMAC adjusts not only the transmission power but also the carrier sensing threshold.

Another approach that incorporates power control is called *topology control*, which determines a common minimum transmission power for such networks to be used by all nodes so that the networks are connected [21,26,27].

The slotted symmetric power in [23] divides the time into large slots, and each large slot contains small slots. In each small slot, nodes turn their maximum power values to a fixed value (meaning that the transmission powers are P_1 and P_2 in small slot i and small slot $i + 1$ and so on). After each large slot, nodes begin to use the same sequence of power values again. A global position system is employed in each node to synchronize the network, and the slotted symmetric power does not utilize multiple channels.

A recent study shows that the capacity of multi-channel multi-radio wireless networks can be increased by exploiting power control [7]. For multi-channel networks, much research work of TPC has been done for centralized networks [28–30]. A centralized polynomial-time linear programming with sequential fixing is proposed in [31] to solve the joint power/rate control and channel assignment problem. Our focus is on distributed multi-hop ad hoc networks. In [32], the authors proposed a distributed power allocation utilizing game theory in cognitive radio networks. Extra monitoring stations are required, and time synchronization is assumed for both user nodes and the extra monitoring stations for their distributed algorithm. The authors in [33] used game theory to propose a distributed algorithm to achieve distributed power control in cognitive radio networks. Similar to [32], the proposed distributed power control in [33] assumes that monitoring sensors are placed on the edge of the primary network cell by the secondary network and that secondary users are synchronized. A distributed power control for cognitive

[‡]In this paper, we use the term the symmetrical (asymmetrical) mode and the symmetrical (asymmetrical) DPL protocol interchangeably.

networks is proposed in [34], and secondary users adjust their transmission power according to the primary link control feedback. In addition, the secondary users operate on only one licensed channel.

Wu *et al.* proposed the DCA-PC protocol [8], which is an extension of the dynamic channel assignment (DCA) protocol [18] that sets the power levels of all channels to the maximum level. They showed that DCA-PC performs better than DCA because of power control. DCA-PC resolves three problems: channel assignment, medium access, and power control. DCA-PC does not require any kind of synchronization among nodes, so does our proposed protocol. Whenever a node has a packet to transmit, it must compete over the control channel to reserve a data channel. The channel assignment occurs on an *on-demand* basis. For example, sender S negotiates with receiver R over the control channel by using RTS, CTS, and reservation (RES) packets with the highest power to select a data channel and determine the necessary power for the data transmission. Thus, DCA-PC creates asymmetric links over any data channel, or, specifically, tends to be similar to BASIC over each data channel. Comparing our proposed DPL protocol with the DCA-PC protocol, there are two major differences. First, DPL forces a node in the network to select an idle channel on the basis of the received power and its corresponding required transmission power (i.e., composing between channel assignment and power control), whereas DCA-PC allows the node to select an idle channel regardless of the received power (i.e., decomposing between channel assignment and power control). Second, DPL allocates different maximum allowable power values to different channels, and nodes only transmit at a power that is less than or equal to the allocated power of a selected channel. However, DCA-PC does not have this constraint.

In [35], a multi-channel power-controlled directional MAC protocol is proposed, and the protocol has two radio interfaces. One interface is an omnidirectional antenna and fixed on the control channel, whereas the other one is a directional antenna and switchable between data channels. Nodes exchange RTS and CTS packets at the maximum power over the control channel to determine the minimum required power, selected data channel, and direction. The proposed multi-channel power-controlled directional MAC protocol selects an idle data channel without power constraint, but because it uses a directional antenna on data channels, the uncontrolled asymmetrical transmission power problem does not occur even though the problem has not been mentioned.

An intelligent MAC with busy tones and power control protocol is introduced in [36]. Specifically, it uses a dual busy tone multiple access protocol [37] with power control. The common bandwidth is divided into four sub-channels: a data channel, a control channel, a narrow-band transmit tone (BT_t), and a narrow-band receive tone (BT_r). The BT_t and BT_r tones indicate whether there is a transmission or reception, respectively. If there is no signal over BT_r , a sender transmits an RTS packet at

the maximum power. However, if the sender senses BT_r to be busy, the sender transmits at the minimum power computed by the received power signal from BT_r . If the receiver senses BT_t to be idle, the receiver transmits a CTS packet and turns its busy receive tone BT_r on. Otherwise, the receiver ignores the RTS packet. An enhancement of the aforementioned protocol is presented in [38]. There is only one data channel, which does not exploit multiple channels.

Nasipuri *et al.* divided the whole bandwidth into M non-overlapping channels [39]. A node in the network can transmit or receive over all channels, but it is allowed to transmit or receive over only one channel at a time. All nodes have the capability of listening to all channels and select their channels that have the minimum interference, and this implies the nodes have the same number of interfaces as the channels. However, it is unpractical to have as many wireless interfaces as channels in each node (e.g., IEEE 802.11a has 12 channels).

The multi-channel MAC (MMAC) protocol is proposed by So and Vaidya [40] to utilize all available channels. They solved the multi-channel hidden terminal problem by synchronization. At the beginning of the ad hoc traffic indication message (ATIM) window, nodes turn their transceivers into the default channel. A pair of nodes reserves a channel by exchanging ATIM, ATIM-ACK, and ATIM-RES packets during the ATIM window. After the ATIM window, the successful pairs turn their transceivers to their agreed channels (including the default channel). Then, the nodes start transmitting following the IEEE 802.11 MAC standard. Each node has a single half-duplex transceiver, which is able to switch between channels. In [41], TMMAC is proposed and extended with the same idea as MMAC to enable the nodes that have not exchanged ATIM, ATIM-ACK, and ATIM-RES packets during the ATIM window to sleep after the ATIM window. MMAC and TMMAC require tight clock synchronization, which is difficult to achieve in multi-hop networks [42–44].

Bahl *et al.* introduced the Slotted Seeded Channel Hopping (SSCH) protocol [13] to improve the capacity of wireless LAN. SSCH is a link layer over the IEEE 802.11-compliant wireless interface and is a distributive protocol for choosing a channel. This protocol requires only one radio interface and follows the parallel rendezvous approach [45]. The sender must synchronize partially with the receiver. If the number of nodes more than twice the previous occurrence is synchronized, the protocol desynchronizes the nodes in order to avoid congestion. The channel is scheduled on the basis of the prime module. The efficient multichannel MAC (EM-MAC) protocol is proposed in [46]. EM-MAC is a duty-cycling MAC protocol and follows the parallel rendezvous approach, similar to SSCH. However, SSCH and EM-MAC suffer from the busy receiver problem [15,47]. A comparison of different multi-channel MAC protocols is presented in [45].

3. DEFICIENCY OF UNCONTROLLED ASYMMETRICAL TRANSMISSION POWER IN MULTI-CHANNEL MULTI-HOP NETWORKS

This section details the deficiency of uncontrolled asymmetrical transmission power, another form of the hidden terminal problem that wastes the channel bandwidth, in multi-channel networks [3–5,40].

Figure 1(a) illustrates this problem. Suppose each node has two transceivers: one is fixed on the control channel to reserve a data channel, and the other is switchable between data channels. RTS and CTS packets are transmitted over the control channel, and data and ACK packets are transmitted over any reserved data channel. In addition, physical carrier sensing is used before transmitting. TPC is also used and determined via RTS/CTS handshaking. The maximum power is emitted over the control channel, and minimum required powers are applied over any selected data channels. The illustrated protocol is similar to the DCA-PC protocol [8].

Without loss of generality, suppose that node A has a packet for node B. To obtain a data channel, node A transmits an RTS packet, which attaches its free channel list available at A, at the maximum transmission power. If node B successfully receives the RTS packet, node B selects a data channel, determines the minimum transmission power, and transmits a CTS packet, which includes the selected channel and the minimum power, over the control channel. For example, as shown in Figure 1(a), if node B chooses Channel 3, then nodes A and B turn their transceivers to Channel 3. Before transmitting, node A must sense the channel for a certain amount of time to avoid collisions (e.g., the distributed interframe space (DIFS) period). If no transmission exists within the carrier sensing range of node A, node A starts the transmission by using the determined minimum power. As shown in Figure 1(a), node C cannot decode the CTS packet

correctly because node C is not within the transmission range of node B.

If node C has a packet for node D, node C follows the same procedure as node A to select a data channel; thus, nodes C and D may choose Channel 3 for the data transmission. Node C must sense Channel 3 before transmitting the packet to node D. Because node A is transmitting at a low power, node C assumes that the channel is idle and starts transmitting. Meanwhile, node D determines the transmission power emitted from node C. Three cases are possible: (1) node C transmits at the same power as node A, such case has been studied in [48]; (2) node C transmits at a low power than node A, in which case node C might not interfere with the ongoing transmission between nodes A and B; and (3) node C is required to transmit at a higher power than node A, leading to a possible collision over Channel 3 at node B. In our example, node C transmits at a higher power than node A, so node C might interfere with the transmission between nodes A and B. Figure 1(b) shows different transmission ranges, which is the top view of Figure 1(a).

Figure 2 shows how the asymmetrical transmission power problem occurs *without having control* over any data channel. Nodes transmit RTS and CTS packets at the maximum power over the control channel (e.g., Channel 1), and data and ACK packets at any minimum power over any data channel. In the figure, node A cannot sense the hidden power from node H over Channel 2, assuming node H starts the transmission before node A. Thus, node H is interfered by node A. At the same time, because node E cannot sense the ongoing transmission between nodes C and D over Channel 3, it interferes with the ongoing transmission. This problem depends on the node distribution, node density, and traffic load, and it is likely that the problem can occur when there are few channels in the network.

In single-channel networks, Xu *et al.* studied the effectiveness of the RTS/CTS packets where all nodes transmit all packets at the highest power [48]. In [3], the authors studied the power control induced hidden terminal

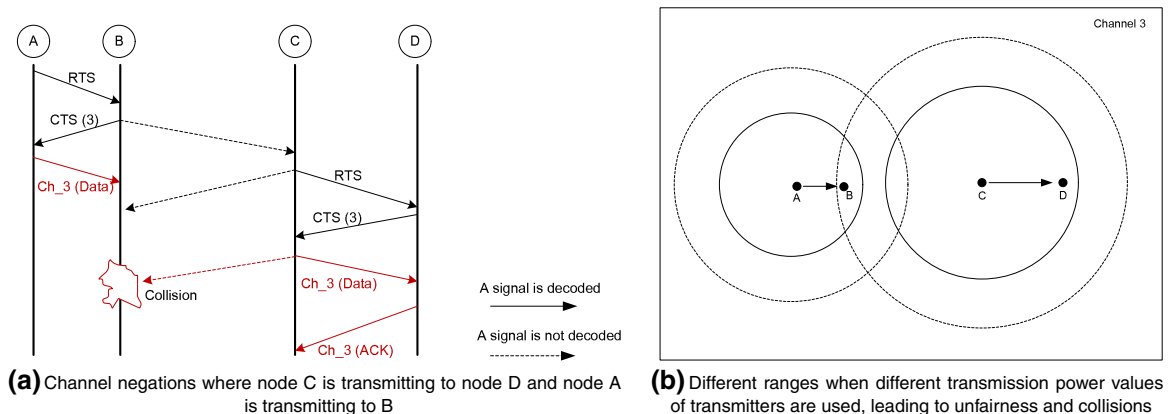

Figure 1. The illustration of the uncontrolled asymmetrical transmission power problem in multi-channel environments.

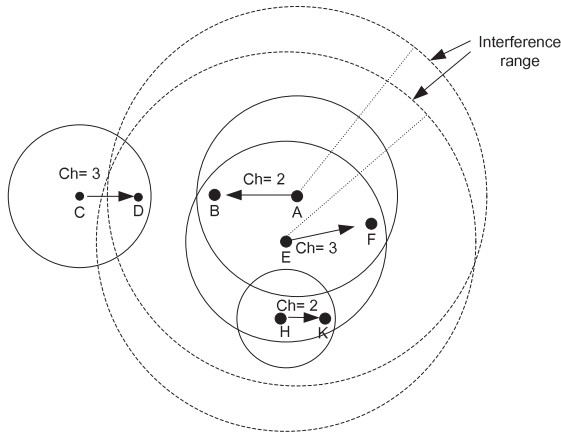

Figure 2. The asymmetrical transmission power can occur without control over multiple channels.

problem, which the interferer always transmits at the maximum power because RTS and CTS packets are transmitted at the maximum power. In multi-channel networks, RTS and CTS packets are transmitted at the maximum power over the control channel, whereas data and ACK packets are transmitted at a power that is equal to or less than the maximum power on any data channel. In the following discussion, we analyze the effect of asymmetrical transmission power over a single channel, and the analysis can be applied to multiple channels. This problem has not been well studied.

A packet is received correctly if $SINR \geq T_{SINR}$, where $SINR$ is the signal-to-interference-plus-noise ratio and T_{SINR} is the threshold to accept the packet. With the two-ray path loss model, the received power at the receiver is calculated as

$$P_r = P_t^t \frac{G_t G_r h_t^2 h_r^2}{d^k} \quad (1)$$

where P_t^t is the transmission power from a transmitter (P_t^t can be less than, or equal to, P_{max}), and G_t and G_r are the antenna gains of the transmitter and the receiver, respectively. The antenna heights of the transmitter and the receiver are h_t and h_r , respectively. The distance between the transmitter and the receiver is d , and k is the path loss exponent, which is equal to 4. In this paper, we focus on the homogeneous wireless network, meaning that all nodes share the same parameters[§] similar to [48]. Consider that one interfering node, which has a distance r from the receiver, is presented, so the receiver measures $SINR$ as follows:

$$SINR = \frac{P_r}{P_i} = \frac{P_t^t \frac{G_t G_r h_t^2 h_r^2}{d^k}}{P_t^i \frac{G_t G_r h_t^2 h_r^2}{r^k}} = \left(\frac{P_t^t}{P_t^i} \right) \left(\frac{r}{d} \right)^k \quad (2)$$

[§] G_t is equal to G_r , which is 1, and h_t is equal to h_r , which is 1.5 m. T_{SINR} is equal to 10. These values are the default values in the ns-2 simulator [49].

where P_i is the interference received power at the receiver, and P_t^i is the transmission power from the interferer (P_t^i is less than, or equal to, P_{max}). In (2), we neglect the thermal noise because the interference received power is much higher than the thermal noise. If P_t^t is equal to P_t^i , then $SINR$ depends only on the ratio distance between the interferer and transmitter distances as follows:

$$SINR = \frac{P_r}{P_i} = \left(\frac{r}{d} \right)^k \geq T_{SINR} \quad (3)$$

However, when the transmission power is different from node to node, $SINR$ is different:

$$SINR = \frac{P_r}{P_i} = \left(\frac{P_t^t}{P_t^i} \right) \left(\frac{r}{d} \right)^k \geq T_{SINR} \quad (4)$$

If (P_t^t/P_t^i) is much less than 1, with high probability, $SINR$ is less than T_{SINR} . In this case, a transmission might fail (i.e., a collision might occur); therefore, it results in unfairness[¶] because the nodes that transmit at higher transmission power values send their packets correctly. Figure 3 illustrates (4) where P_t^t and P_t^i vary from one of the following power values: 281.1, 56.4, and 18.8 mW; their corresponding transmission ranges are 250, 167, and 127 m, respectively. In Figure 3, the shadowed areas are the vulnerable areas in which $SINR$ is less than 10 at the receiver; in other words, a collision occurs at the receiver. Note that when the transmitter sends its packet at a lower power than the interferer, the shadowed areas increase. However, when the transmitter sends its packet at a higher power than the interferer, the shadowed areas decrease.

In summary, to design a TPC protocol, the transmission power transmitted over a channel should be the same (e.g., $P_t^t/P_t^i = 1$) or be approximately the same (e.g., $P_t^t/P_t^i \approx 1$). This design yields to a fair share of a channel among nodes. The higher the value of the transmission power is, the greater interference exists [50].

4. DISTRIBUTED POWER LEVEL FOR MULTI-CHANNEL AD HOC NETWORKS

This section presents our novel distributed DPL protocol for multi-channel ad hoc networks. The key idea behind our proposed protocol is to differentiate allowable transmission power levels among channels. In other words, different transmission power levels are assigned to different channels. In the following, we first summarize our assumptions followed by the list structures and then briefly explain the channel selection of our protocols in Section 4.3. In Section 4.4, we present the symmetrical and asymmetrical DPL modes. Finally, we present the implementation of DPL.

[¶]The capture effect problem may occur and result in unfairness.

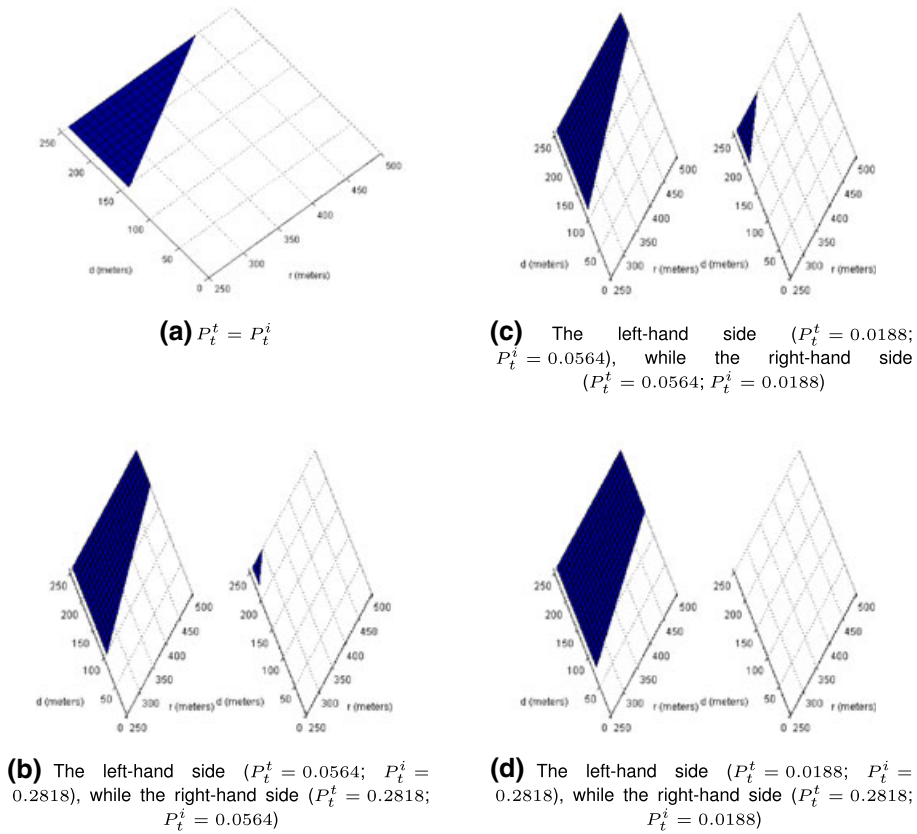

Figure 3. The effect of using different transmission power over a channel. The shadowed areas are the vulnerable areas where collisions occur.

4.1. Assumptions

- There are M channels that have equal bandwidths, where all channels are able to carry information. One channel is known as the control channel, and the remaining $M - 1$ channels are data channels. We treat channels as a set of bandwidths in the spectrum domain. All broadcast and control packets are transmitted over the control channel.
- Each node is equipped with two interfaces. The two interfaces are installed separately from each other (approximately half of the waveform) without interfering with each other. Therefore, the two interfaces can operate simultaneously. Each interface is a half-duplex transceiver, meaning that it cannot transmit and receive at the same time. One interface is fixed on the control channel, and the second interface is able to switch between data channels.
- Nodes transmit over the control channel at the maximum power P_{\max} . However, each data channel is associated with a maximum allowable transmission power as shown in Figure 4. For example, the maximum allowable power of the data channel i is set to be P_i^{\max} , where $P_{\max} = P_1^{\max} \geq P_2^{\max} \geq P_3^{\max} \geq \dots \geq P_M^{\max}$. The power assignment is known prior to the nodes in the network (i.e., the power

assignment is configured before the nodes join the network); therefore, the stability and convergence issues do not exist in our proposed protocol. Note that the notion of the transmission power of a node is not the same as the maximum allowable power of a data channel (e.g., the transmission power of node A is P_t^A and the maximum allowable power of the data channel i is P_i^{\max}) and that the node is able to change its transmission power, but not the power assignment ($P_1^{\max}, P_2^{\max}, \dots, P_M^{\max}$). In this paper, we choose the power assignment *arbitrarily* (i.e., no optimization is considered), and we study the impact of different power assignments on the network throughput in Section 5.

4.2. List structures

Each node maintains two local list structures: a node allocation list (NAL) and a channel allocation list (CAL). NAL maintains nodes' activities, and CAL monitors the information of data channels. These lists are maintained by listening to the control channel. A node updates its NAL and CAL whenever it receives any of RTS, CTS, or RES packets. NAL contains the following three fields: *nodeID* (identification of a node), *duration* (duration how

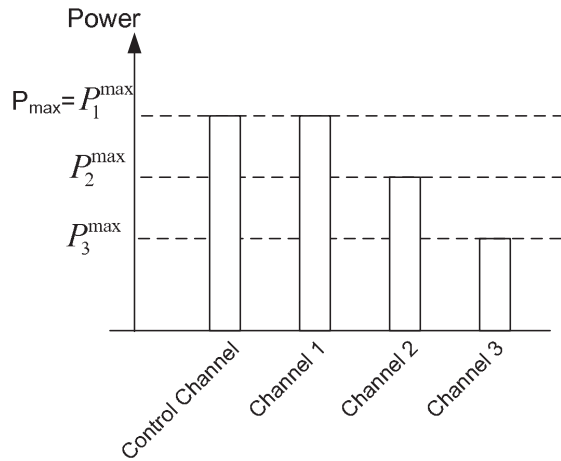

Figure 4. Different allowable powers over different channels.

long node *nodeID* has been busy), and *preChannel* (preferred channel to reach node *nodeID*). The received power of node *nodeID* is equal to or less than the maximum power of Channel *preChannel* ($P_{preChannel}^{max}$), and the *preChannel* field is continuously updated.

Channel allocation list has the following three fields: *chID* (identification of a channel), *duration* (time duration indicates how long Channel *chID* has been busy), and P_{chID}^{max} (the maximum allowable power assigned to Channel *chID*). The *duration* field is important to avoid the multi-channel hidden problem [40], and the P_{chID}^{max} field of channel *chID* is fixed and does not change.

One more list that is generated from CAL is called an available channel indicator (ACI) list, which indicates whether Channel *i* is free ($ACI(i) = 1$) or not ($ACI(i) = 0$). Before a node transmits an RTS packet, the node must generate a new ACI list and include the new ACI list in the

RTS packet. Therefore, a receiving node can look for an idle data channel.

4.3. Channel selection

The MAC protocol uses a dedicated control channel and multiple data channels as illustrated in Figure 5, followed the RTS/CTS/RES handshaking, similar to that of the DCA protocol [18], because clock synchronization is not required.

In DCA-PC, receivers select any idle data channel without any restriction. However, in DPL, receivers select a data channel on the basis of the received power so that the maximum allowable power of the data channel is larger than or equal to the received power. If the data channel of the least maximum power is busy, nodes are able to select the next data channel and so on. For example, when node A needs to transmit a data packet to node B, node A first transmits to node B an RTS packet, which includes the free channel list that node A is able to use. When node B receives the RTS packet, it measures the received power. Next, node B searches for a free channel on the basis of the received power, so the maximum allowable power of the channel must be larger than or equal to the received power; at the same time, both nodes A and B are able to use the channel. If node B is able to use Channel 3, but Channel 3 is busy, then node B can select Channel 2 (because of $P_2^{max} \geq P_3^{max}$). If Channel 2 is free, node B transmits a CTS packet over the control channel by using P_{max} . Upon receiving the CTS packet, node A transmits its packet to node B over Channel 2. After the short interframe space (SIFS) period, node A transmits an RES packet over the control channel. If node B successfully receives the data packet, node B responds to node A with an ACK packet over Channel 2. However, if node B does not find any idle channel, it transmits a CTS packet to node A. The CTS packet does not indicate any selected channel and includes

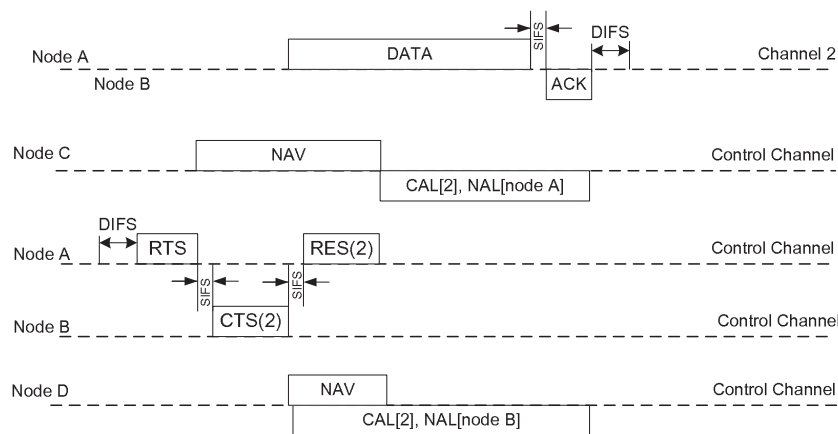

Figure 5. The medium access control protocol using a dedicated control channel and multiple data channels. SIFS, short interframe space; ACK, acknowledgement; DIFS, distributed interframe space; NAV, network allocation vector; RTS, request to send; RES, reservation; CTS, clear to send; CAL, channel allocation list; NAL, node allocation list.

the minimum time for node A to start over again (i.e., node A restarts the negotiation process). Section 4.5 presets the details of the proposed protocol.

4.4. Power control

The DPL protocol sets different emission powers over different data channels. A node computes the minimum required power and then selects a data channel whose power is equal to or greater than the minimum power. As a result, the node that need higher transmission power selects a different channel from the node that requires lower transmission power.

Two power control modes are introduced for DPL. First, the symmetrical DPL protocol maintains symmetrical links over all channels (e.g., over Channel i , all nodes are required to transmit at P_i^{\max}). For example, if node A prefers Channel 3 to transmit a packet to node B and Channel 3 is busy, then node A can use Channel 2 but transmits the packet at $P_1^A = P_2^{\max}$ (not P_3^{\max}). Second, the asymmetrical DPL protocol adjusts the transmission power over a channel so that nodes are allowed to transmit at the minimum power if necessary. As a result, the asymmetrical DPL protocol decreases interference over any data channel and is beneficial especially when nodes take a longer time to transmit a packet. Note that, by using the asymmetrical DPL protocol, nodes do not always create asymmetrical links over data channels, but nodes decrease their powers if the preferred channels are busy. For example, if node A can reach node B by using Channel 3 and Channel 3 is busy, then node A is able to transmit a packet to node B by using Channel 2 at $P_1^A = P_3^{\max}$ (not P_2^{\max}).

4.5. Operations

To explain how the proposed protocol operates, we use an example shown in Figure 5. Suppose node A has a packet for node B, node C is within the transmission range of node A, and node D is within the transmission range of node B. Table I presents the list of the symbols, and Figure 5 shows how the MAC protocol works. The details of DPL are presented in the following steps.

Step 1. In order for node A to transmit an RTS packet, three conditions must be satisfied:

- (1) Node B is not busy, which is

$$NAL[B].duration \leq NOW + T_{DIFS} + T_{RTS} + T_{SIFS} + T_{CTS} + 2\tau \quad (5)$$

where NOW is the current time of node A, T_{DIFS} is the time length of DIFS, T_{RTS} is the duration to transmit an RTS packet, T_{SIFS} is the time length of SIFS, T_{CTS} is the duration to transmit a CTS packet, and τ is the maximum propagation delay.

Table I. List of symbols.

R_d	The rate of the data channel
R_c	The rate of the control channel
τ	Maximum propagation delay
L_d	Payload length of a data frame
L_{ACK}	Payload length of an acknowledgement frame
T_{DIFS}	Time duration of the distributed interframe space
T_{SIFS}	Time duration of the short interframe space
T_{RTS}	Time to transmit a request-to-send frame
T_{CTS}	Time to transmit a clear-to-send frame
T_{RES}	Time to transmit a reservation frame
NOW	The local current time in each node
T_{data}	Time duration of a complete data transmission
	$T_{data} = L_d/R_d + T_{SIFS} + L_{ACK}/R_c + 2\tau$
P_{max}	The maximum transmission power
P_i^{max}	The maximum transmission power for Channel i
P_{min}	The minimum required power for a data transmission
P_r	The received power
T_{SINR}	The threshold power to accept a packet

- (2) There is at least one available data channel that must be available, and there are two cases. The first case is when node A does not know the preferred channel of node B, and node A searches for all the available data channels, such that

$$CAL[i].duration \leq NOW + T_{DIFS} + T_{RTS} + T_{SIFS} + T_{CTS} + 2\tau \quad (6)$$

for all i . The second case is when node A knows the preferred channel of node B, and node A searches for the data channels whose maximum allowable powers are greater than or equal to the power of the preferred channel of node B by using (6) for all $i \leq NAL[B].preChannel$, where $preChannel$ is the preferred channel to reach node B.

- (3) The control channel is idle for DIFS, following the IEEE 802.11 MAC standard.

If all the aforementioned conditions are satisfied, node A transmits the RTS packet, which includes the packet size (L_d) and the ACI that node A is able to use. Otherwise, node A defers its transmission; that is, node A performs a standard backoff procedure. If the control channel is idle, node A rechecks conditions (1) and (2). If conditions (1) and (2) are not satisfied, node A regenerates another random backoff interval and repeats Step 1.

Step 2. When node B receives the RTS (ACI, L_d) packet successfully, node B has to determine the desired

minimum power[‡] P_{\min} . Because we consider the two-ray path loss model in our model, it can be computed (which is similar to [3,4,8]) as follows:

$$P_{\min} = \frac{P_{\max} T_{\text{SINR}}}{P_r} \quad (7)$$

where T_{SINR} is the threshold power and P_r is the received power. Then, node B compares P_{\min} with transmission powers that are associated with each data channel. Finally, node B selects a data channel that satisfies the two following conditions:

- (1) The power level of the data channel is equal to or greater than P_{\min} , that is, $P_i^{\max} \geq P_{\min}$, $i \in M - 1$.
- (2) The data channel i is idle:

$$\begin{aligned} \text{CAL}[i].\text{duration} \leq (\text{NOW} + T_{\text{SIFS}} + T_{\text{CTS}} \\ + \tau) \wedge (\text{ACI}[i] = 1) \end{aligned} \quad (8)$$

When the channel with the least power is busy (e.g., Channel 3 is the preferred channel to reach node A), node B checks the channel to see if the power level is greater than the least power level. If node B finds a free channel, for example, Channel 2, node B replies to node A with a CTS packet that includes the selected data channel and the transmission duration time, CTS (Ch_i, T_{data}), where $T_{\text{data}} = L_d/R_d + T_{\text{SIFS}} + L_{\text{ACK}}/R_c + 2\tau$, where R_c and R_d are the transmission rates for both control and data channels, respectively. L_d and L_{ACK} are the packet lengths of payload and ACK frames, respectively. Meanwhile, node B switches its switchable interface to the selected channel and updates its lists as follows:

$$\begin{aligned} \text{NAL}[A].\text{duration} &= T_{\text{data}} + T_{\text{CTS}} + \\ &T_{\text{SIFS}} + \tau, \\ \text{NAL}[A].\text{preChannel} &= Ch_3, \\ \text{CAL}[2].\text{duration} &= \text{NAL}[A].\text{duration} \end{aligned} \quad (9)$$

However, if all channels that satisfy the least power are busy, node B sends a CTS (T_{\min}) packet including the minimum waiting time (T_{\min}) (i.e., $T_{\min} = \min\{\text{CAL}[i].\text{duration}\}$, for all $i \leq \text{NAL}[A].\text{preChannel}$) after SIFS. Moreover, node B updates only the preferred channel to reach to node A, that is, $\text{NAL}[A].\text{preChannel} = Ch_3$.

Step 3. If node A receives the CTS (Ch_i, T_{data}) packet that has a selected channel, Ch_i , for example, Channel 2, then node A measures the received

power of the CTS packet and determines the preferred channel to reach node B. Moreover, node A switches its second interface to the selected data channel and starts transmitting the data packet. Node A transmits its packet over Ch_i at a power according to the power controls described in Section 4.4. After the SIFS duration, node A transmits an RES packet that contains the selected channel and the remaining transmission duration over the control channel, RES (Ch_i, T_{rem}), where $T_{\text{rem}} = T_{\text{data}} - T_{\text{RES}} - T_{\text{SIFS}} - \tau$. At the same time, node A updates its lists as follows:

$$\begin{aligned} \text{NAL}[B].\text{duration} &= T_{\text{data}}, \\ \text{NAL}[B].\text{preChannel} &= Ch_3, \\ \text{CAL}[2].\text{duration} &= T_{\text{data}} \end{aligned} \quad (10)$$

However, if node A receives the CTS (T_{\min}) packet, indicating that there is no available channel, node A defers its transmission for at least T_{\min} , specified by node B. After that, node A returns to Step 1.

Step 4. If node A does not receive the CTS packet within the $T_{\text{SIFS}} + T_{\text{CTS}} + 2\tau$ interval, then node A assumes that the RTS packet is collided, doubles the contention window, counts the number of retries, and goes to Step 10.

Step 5. Whenever node C receives the RTS packet from node A, it measures the received power, determines the preferred channel, for example, Channel 4, that reaches node A, and refreshes its NAL (i.e., $\text{NAL}[A].\text{preChannel} = Ch_4$). Moreover, node C updates its network allocation vector (NAV) field (i.e., $\text{NAV} = T_{\text{CTS}} + T_{\text{RES}} + 2T_{\text{SIFS}} + 2\tau$) so that node C does not interrupt the channel negotiation between nodes A and B.

Step 6. If node D receives the CTS (Ch_i, T_{data}) packet, which $Ch_i = 2$, from node B, node D measures the received power of the CTS packet, determines the reachable channel for node B, and updates its lists as follows:

$$\begin{aligned} \text{NAL}[B].\text{duration} &= T_{\text{data}} + \tau, \\ \text{NAL}[B].\text{preChannel} &= Ch_2, \\ \text{CAL}[2].\text{duration} &= T_{\text{data}} + \tau \end{aligned} \quad (11)$$

In addition, node D updates its NAV field (i.e., $T_{\text{SIFS}} + T_{\text{RES}} + \tau$) so that node D does not interfere with node A. However, when the CTS packet does not have a selected data channel, node D measures the received power of the CTS packet, determines the reachable channel for node B, and updates its NAL list.

Step 7. When node C hears the RES (Ch_i, T_{rem}) packet from node A, node C first measures the received power of the RES packet, then evaluates the

[‡]In reality, the desired required power takes into account both the large-scale effect and the small-scale effect.

preferred channel, for example, Channel 4, for node A, and finally updates its lists as follows:

$$\begin{aligned} NAL[A].duration &= T_{\text{rem}}, \\ NAL[A].preChannel &= Ch_4, \\ CAL[2].duration &= T_{\text{rem}} \end{aligned} \quad (12)$$

- Step 8.* When node B receives the data packet with no errors over Ch_i , it waits for SIFS and replies to node A with an ACK packet over the same channel. If the packet has errors, node B just ignores it.
- Step 9.* If node A does not receive any ACK packet within the $T_{\text{ACK}} + T_{\text{SIFS}} + \tau$ interval after transmitting its data packet, then node A doubles the contention window, counts the number of retries, and goes to Step 10. The data transmission is completed if node A receives the ACK packet; therefore, node A resets the number of retries and the contention window, schedules the next packet, and goes to Step 1.
- Step 10.* If the number of retries reaches the maximum number of retries, then the packet is dropped, and the contention window is reset. Node A schedules the next packet and goes to Step 1. If the number of retries has not reached the maximum number of retries, node A goes to Step 1.

5. PERFORMANCE EVALUATION

This section presents the performance evaluation of the symmetrical and asymmetrical DPL modes, and our performance metric is the aggregate throughput of all flows in the network. We compare our proposed protocols with DCA-PC [8] and 802.11 MAC. The DPL and DCA-PC protocols use a dedicated control channel for exchanging the control packets and the remaining channels for data transmissions; however, the main differences are the design of TPC and the channel assignment strategy.

5.1. Simulation model

We have implemented our proposed protocols and DCA-PC [8] on ns-2 (version 2.30) [49], and the simulation parameters are provided in Table II. The radio interface parameters follow the Lucent's WaveLAN parameters. The carrier sensing range is approximately twice the communication range, and the radio propagation model is the two-ray path loss model. With the use of the maximum power, the communication range is 250 m, and the carrier sensing range is about 550 m. In addition, the channel bit rates are for the control channel and data channels are 1 and 2 Mbps, respectively.

Four channels are available in the network unless otherwise mentioned. The transmission powers assigned to each channel are 281.1, 281.1, 56.4, and 18.8 mW, respectively; their corresponding transmission distances

Table II. System parameters used in simulations.

Parameters	Values
Carrier sense threshold (mW)	1.56×10^{-8}
Receiver sensitivity (mW)	3.65×10^{-7}
T_{SINR}	10
Maximum transmission power P_{max} (mW)	281.8
Transmission rate for data channels (Mbps)	2
Transmission rate for the control channel (Mbps)	1
Retry limit	7
DIFS (μs)	50
SIFS (μs)	10
Slot time (μs)	20
CW_{min}	32
CW_{max}	1024
Maximum propagation delay τ (μs)	1
RTS (bits)	$208 + PHY_{\text{hdr}}$
CTS (bits)	$256 + PHY_{\text{hdr}}$
RES (bits)	$208 + PHY_{\text{hdr}}$
ACK (bits)	$112 + PHY_{\text{hdr}}$
MAC_{hdr} (bits)	272
PHY_{hdr} (bits)	192

are 250, 250, 167, and 127 m, respectively. The first channel is the dedicated control channel, and the remaining channels are data channels.

In the simulations, no mobility and the constant bit rate traffic model are assumed. Each point in the simulation results is the average over 30 different scenarios, and each simulation lasts 100 s. We consider two different types of topologies for simulations:

- **Chain topology** consists of 30 nodes. As shown in Figure 6, node 1 sends to node 2, node 2 sends to node 3, and so on. As a result, there are 29 flows. The packet size is 512 bytes, and the distance between two adjacent nodes is uniformly distributed between 20 and 230 m.
- **Random topology** includes 50 wireless nodes deployed randomly in a 1000 m \times 1000 m square area. Each node randomly chooses its destination located within its communication range. As a result, there are 50 flows, and a node could be involved in multiple communications.

5.2. Simulation results

This section presents and discusses the simulation results under different topologies. We first show the aggregate

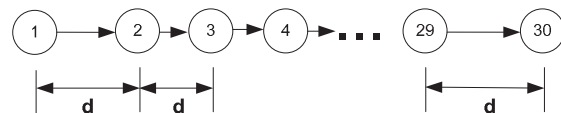

Figure 6. A chain topology consists of 30 nodes and 29 flows, and the distance d between two nodes is a uniform random variable between 20 and 230 m.

throughput of the chain topology with different network loads. We then show the aggregate throughput of the random topology in terms of various network loads, packet sizes, sensitivity of power assignments, and number of channels.

Figure 7 shows the simulation results of 30 nodes arranged in the chain topology. In the figure, we simulate the network with different loads. As the data rate per flow increases, the throughput of all protocols increases. However, as the network load increases, the proposed protocols outperform the DCA-PC protocol because it suffers from the uncontrolled asymmetrical transmission power problem. Note that the throughputs of the asymmetrical and symmetrical DPL protocols are identical because of low node density and short data transmission time.

Figure 8 shows the aggregate throughput of the random topology when the packet size is 1000 bytes and the number of channels is 4. It can be seen that as the flow data rate increases, the network throughput can be improved for all protocols. When the network load is low, DCA-PC achieves better performance than the proposed protocols because the uncontrolled asymmetrical transmission power problem does not occur. However, the symmetrical and asymmetrical DPL protocols achieve the best performance for high data rate. In addition, the asymmetrical DPL protocol achieves a slightly higher throughput than the symmetrical DPL protocol because it may adjust the transmission power over any channel and thereby reducing interference as mentioned in Section 4.4.

Figure 9 shows the network throughput of the random topology for different packet sizes. We assume that the rate of each flow is 1 Mbps, and the number of channels is 4. As the packet size increases, the aggregate throughput of all protocols increase. Both the asymmetrical and symmetrical DPL protocols outperform the other protocols because the interference over channels emitted from the proposed

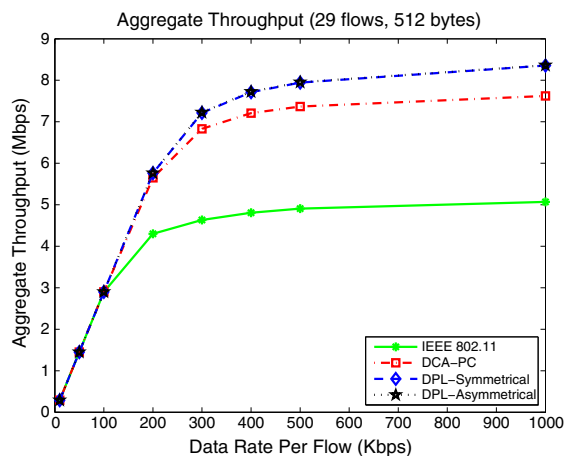

Figure 7. Aggregate throughput in the chain topology with different network loads.

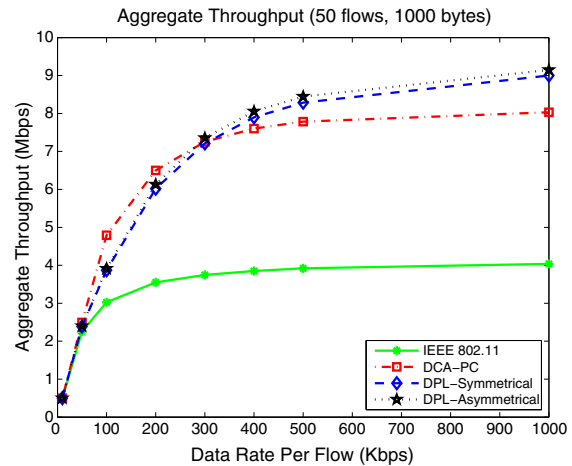

Figure 8. Aggregate throughput in the random topology with different network loads.

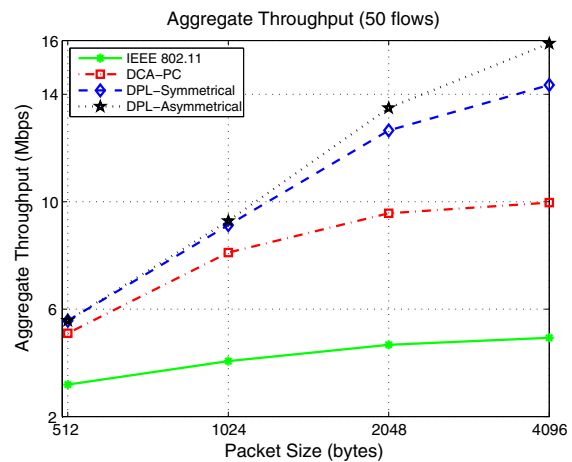

Figure 9. Aggregate throughput versus packet size in the random topology.

protocols are lower. However, the asymmetrical protocol achieves the highest throughput because it emits the lowest interference. Figure 10 shows the aggregate throughput of 30 different scenarios when the rate of each flow is 1 Mbps for two different packet sizes (1024 bytes as shown in Figure 10(a) and 2048 bytes as shown in Figure 10(b)). Each point shown in the figures represents one scenario averaged over time. When the packet size is 2048 bytes, the performance difference between the asymmetrical DPL protocol and the symmetrical DPL protocol is more obvious.

Next, we examine the sensitivity of the aggregate throughput on power assignments. There are many factors affecting the best power assignment. Such factors are node density, network topology, traffic flow, mobility, and number of channels. Table III presents the throughput of

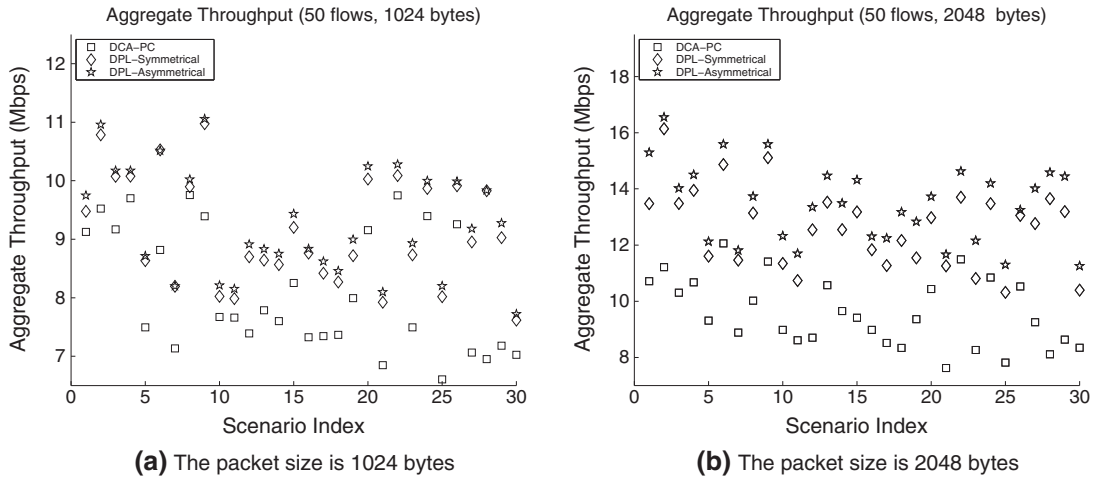

Figure 10. Aggregate throughput of 30 different scenarios in the random topology. DCA-PC, dynamic channel assignment with power control.

Table III. Sensitivity of throughput based on power assignments in the random topology.

Power assignment	$(P_1^{\max}, P_2^{\max}, P_3^{\max})$ mW (d_1, d_2, d_3) m	Throughput (Mbps)	
		DPL-symmetrical	DPL-asymmetrical
PA-1	(281.8, 281.8, 9.36) (250, 250, 100)	6.949792	7.193493
PA-2	(281.8, 281.8, 17.61) (250, 250, 125)	7.275610	7.565689
PA-3	(281.8, 281.8, 28.18) (250, 250, 140)	7.215666	7.587570
PA-4	(281.8, 281.8, 115.42) (250, 250, 200)	6.145187	6.539171

DPL, distributed power level.

different power assignments when the number of channels is 3. Note that the first channel is the dedicated control channel, and the allowable transmission power is set to the maximum transmission power. To maintain the network connectivity, the second channel is also set to the maximum transmission power. The third channel is the only channel that we can change its maximum allowable power. In Table III, the throughput changes when the power assignment changes. Using power assignment 1 (PA-1), both the asymmetrical and symmetrical DPL protocols achieve better performance than that of using PA-4 because the transmission range of Channel 3 using PA-4 is 200 m, which is near the transmission range of the maximum transmission power P_{\max} and that is 250 m. Because the network topology is random, the ideal transmission range for Channel 3 is approximated as half of the maximum transmission range (≈ 125 m). The asymmetrical DPL protocol does not agree with the symmetrical DPL protocol on choosing the same power assignment. From Table III, the asymmetrical DPL protocol achieves its highest throughput by using

PA-3, whereas the symmetrical DPL protocol achieves its highest throughput by using PA-2. This difference occurs because the symmetrical DPL protocol uses the same transmission power that is assigned to a channel, but the asymmetrical DPL protocol could adjust the transmission power over any channel as presented in Section 4.4.

Finally, we examine the impact of the number of channels on the network throughput. We assign different maximum transmission powers to different numbers of channels as shown in Table IV. Note that we do not optimize the power assignments; our power assignments are chosen arbitrarily. However, from the previous discussions, choosing power assignments does affect the network performance. Figure 11 shows the throughput of the random topology when the number of channel increases from 3 to 8 for two different packet sizes. Note that the IEEE 802.11 MAC protocol has the same performance because it uses a single channel. However, the throughput of DPL and DCA-PC protocols increases when the number of channels increases. From the figure, the proposed

Table IV. Maximum transmission power values and their corresponding transmission distances for different numbers of channels.

Numbers of Channels (M)	$(P_1^{\max}, P_2^{\max}, \dots, P_M^{\max})$ mW (d_1, d_2, \dots, d_M) m
3	(281.8, 281.8, 28.18) (250, 250, 140)
4	(281.8, 281.8, 56.4, 18.8) (250, 250, 167, 127)
5	(281.8, 281.8, 93.93, 40.26, 18.8) (250, 250, 190, 153, 127)
6	(281.8, 281.8, 93.93, 56.36, 28.18, 18.8) (250, 250, 189, 167, 140, 127)
7	(281.8, 281.8, 140.9, 70.45, 35.225, 18.8, 14.09) (250, 250, 210, 176, 148, 127, 118)
8	(281.8, 281.8, 140.9, 70.45, 35.225, 18.8, 14.09, 9.36) (250, 250, 210, 176, 148, 127, 118, 100)

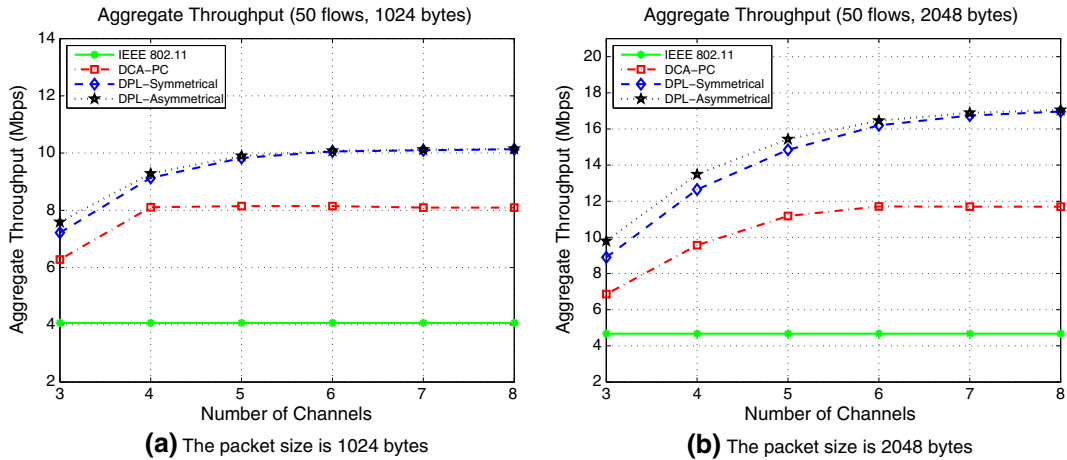

Figure 11. Aggregate throughput versus number of channels in the random topology.

protocols achieve significant throughput improvement than DCA-PC and IEEE 802.11 protocols. Moreover, DCA-PC saturates sooner than the proposed protocols because of the uncontrolled asymmetrical transmission power problem described in Section 3. When the packet size is smaller and the number of channels is larger, the asymmetrical DPL protocol behaves similar to the symmetrical DPL protocol because nodes often transmit over their preferred channels.

6. DISCUSSIONS

One of the techniques that can be used to improve the network performance of both the DPL and DCA-PC protocols is to use a dedicated control channel for data transmissions,

thereby enhancing the network throughput, especially in a network with few channels [51].

The DPL protocol uses a dedicated control channel and multiple data channels, and the main advantage of the approach is that it does not require any kind of synchronization. However, the asymmetrical and symmetrical DPL protocols can be implemented using other multi-channel MAC protocols, such as McMAC [11] or MMAC [40]. In MMAC, whereas the common channel must be set to the maximum power, other channels can be different. MMAC requires one transceiver per node but requires clock synchronization.

The IEEE 802.11a operates in the 5-GHz band, which is known as the unlicensed national information infrastructure band. The bandwidth is divided into non-overlapping channels. Different allowable powers are set to different

Table V. Power allocation for the 5-GHz band.

Frequency Band (GHz)	Maximum allowable power (mW)
5.15–5.25	40
5.25–5.35	200
5.725–5.825	800

channels, and the power values vary from one country to another. The maximum transmission power for the unlicensed national information infrastructure band according to the Federal Communications Commission is provided in Table V [52]. To the best of our knowledge, limited research work actually considers the allowable power over different channels so that the DPL protocols are realistic. Most existing multi-channel MAC protocols for multi-hop ad hoc networks assume that transmission power over different channels is the same.

The proposed DPL protocols assign different power levels to different channels (e.g., the maximum power level of data channel 1 is set to be P_1^{\max} , the maximum power level of data channel 2 is set to be P_2^{\max} , and so on), and different power assignments lead to different throughputs. Therefore, choosing a proper power assignment is very critical. One particular power assignment is to set the same power level for all channels to be equal to the highest maximum transmission power (P^{\max}) so that the symmetrical DPL protocol behaves similarly to the DCA protocol [18], whereas the asymmetrical DPL protocol behaves similarly to the DCA-PC protocol [8].

7. CONCLUSION AND FUTURE WORK

In this paper, we have proposed a novel TPC protocol called the DPL protocol to overcome the uncontrolled asymmetrical transmission power problem in multi-channel ad hoc networks. The proposed protocol allocates different allowable power levels to different channels so that nodes can determine the minimum required transmission power and then select appropriate data channels for their data transmissions. In addition, two TPC modes are introduced for DPL: symmetrical and asymmetrical. For the symmetrical DPL protocol (mode), nodes transmit at the power allocated to the selected data channel. Alternatively, for the asymmetrical DPL protocol, nodes transmit at a lower or equal power level as that assigned to the selected channel. We compare our proposed protocols with existing uncontrolled asymmetrical transmission power protocol (DCA-PC), and the simulation results using ns-2 demonstrate that the proposed protocols can effectively prevent the uncontrolled asymmetrical transmission power problem in multi-channel wireless networks, thereby achieving higher throughput.

In the future, we will develop an adaptive scheme to assign transmission power levels to different channels on the basis of node density and the number of channels. Network performance can also be improved by considering

TPC with data rate adaptation that allows nodes to select channels with the highest data rate.

ACKNOWLEDGEMENTS

This research work was supported by a scholarship from the Ministry of Higher Education of the Government of Saudi Arabia and Umm Al-Qura University, Makkah, Saudi Arabia.

REFERENCES

- Gomez J, Campbell AT. Conserving transmission power in wireless ad hoc networks, In *Proceedings of the Ninth International Conference on Network Protocols (ICNP)*, Riverside, CA, USA, 2001.
- Agarwal S, Katz R, Krishnamurthy S, Dao S. Distributed power control in ad-hoc wireless networks, In *Proceedings of IEEE International Symposium on Personal, Indoor and Mobile Radio Communications (PIMRC)*, vol. 2, San Diego, CA, USA, 2001; F-59-F-66.
- Shih KP, Chen YD, Chang CC. A physical/virtual carrier-sense-based power control MAC protocol for collision avoidance in wireless ad hoc networks. *IEEE Transactions on Parallel and Distributed Systems* 2011; **22**(2): 193–207. DOI: 10.1109/TPDS.2010.75.
- Jung ES, Vaidya NH. A power control MAC protocol for ad hoc networks. *Wireless Networks* 2005; **11**(1-2): 1022–0038. (Print).
- Shih KP, Chen Y. CAPC: a collision avoidance power control MAC protocol for wireless ad hoc networks. *IEEE Communications Letters* 2005; **9**(9): 859–861.
- Krunz M, Muqattash A, Lee S. Transmission power control in wireless ad hoc networks: challenges, solutions and open issues. *IEEE Network* 2004; **18**(5): 8–14.
- Shila D, Cheng Y, Anjali T, Wan PJ. Extracting more capacity from multi-channel multi-radio wireless networks by exploiting power, In *Proceedings of IEEE 30th International Conference on Distributed Computing Systems (ICDCS)*, Genova, Italy, 2010; 858–867.
- Wu SL, Tseng YC, Lin CY, Sheu JP. A multi-channel MAC protocol with power control for multi-hop mobile ad hoc networks. *The Computer Journal* 2002; **45**(1): 101–110.
- Raniwala A, Chiueh TC. Architecture and algorithms for an IEEE 802.11-based multi-channel wireless mesh network, In *Proceedings of IEEE INFOCOM*, vol. 3, Miami, FL, USA, 2005; 2223–2234.

10. Veluppillai M, Mark J, Shen X. Performance analysis and power allocation for M-QAM cooperative diversity systems. *IEEE Transactions on Wireless Communications* 2010; **9**(3): 1237–1247.
11. So HSW, Walrand J, Mo J. McMAC: a parallel rendezvous multi-channel MAC protocol, In *Proceedings of IEEE Wireless Communications and Networking Conference (WCNC)*, Hong Kong, China, 2007; 334–339.
12. Cai J, Liu K, Shen X, Mark J, Todd T. Power allocation and scheduling for ultra-wideband wireless networks. *IEEE Transactions on Vehicular Technology* 2008; **57**(2): 1103–1112.
13. Bahl P, Chandra R, Dunagan J. SSCH: slotted seeded channel hopping for capacity improvement in IEEE 802.11 ad-hoc wireless networks, In *Proceedings of ACM MobiCom*, Philadelphia, PA, USA, 2004; 216–230.
14. Bi Y, Liu KH, Cai LX, Shen X, Zhao H. A multi-channel token ring protocol for QoS provisioning in inter-vehicle communications. *IEEE Transactions on Wireless Communications* 2009; **8**(11): 5621–5631.
15. Crichigno J, Wu MY, Shu W. Protocols and architectures for channel assignment in wireless mesh networks. *Ad Hoc Networks* 2008; **6**(7): 1051–1077.
16. Bahl P, Adya A, Padhye J, Walman A. Reconsidering wireless systems with multiple radios. *ACM SIGCOMM Computer Communication Review* 2004; **34**(5): 39–46.
17. Kyasanur P, Vaidya N. Routing and interface assignment in multi-channel multi-interface wireless networks, In *IEEE Wireless Communications and Networking Conference (WCNC)*, New Orleans, USA, 2005; 2051–2056.
18. Wu SL, Lin CY, Tseng YC, Sheu JL. A new multi-channel MAC protocol with on-demand channel assignment for multi-hop mobile ad hoc networks, In *Proceedings of the International Symposium on Parallel Architectures, Algorithms and Networks (ISPAN)*, Dallas, TX, USA, 2000; 232–237.
19. Almotairi KH, Shen XS. Multichannel medium access control for ad hoc wireless networks. *Wireless Communications and Mobile Computing (Wiley)*. DOI: 10.1002/wcm.1159.
20. Ge W, Zhang J, Wieselthier JE, Shen X. PHY-aware distributed scheduling for ad hoc communications with physical interference model. *IEEE Transactions on Wireless Communications* 2009; **8**(5): 2682–2693.
21. Kawadia V, Kumar P. Principles and protocols for power control in wireless ad hoc networks. *IEEE Journal on Selected Areas in Communications* 2005; **23**(1): 76–88.
22. Muqattash A, Krunz M. A single-channel solution for transmission power control in wireless ad hoc networks, In *Proceedings of MobiHoc*, Tokyo, Japan, 2004; 210–221.
23. Navda V, Kokku R, Ganguly S, Das S. Slotted symmetric power control in managed wireless LANs. *Technical Report*, NEC Labs, 2007.
24. Yu C, Shin KG, Lee B. Power-stepped protocol: enhancing spatial utilization in a clustered mobile ad hoc network. *IEEE Journal on Selected Areas in Communications (JSAC)* 2004; **22**(7): 1322–1334.
25. Li P, Geng X, Fang Y. An adaptive power controlled MAC protocol for wireless ad hoc networks. *IEEE Transactions on Wireless Communications* 2009; **8**(1): 226–233.
26. Ramanathan R, Rosales-Hain R. Topology control of multihop wireless networks using transmit power adjustment, In *Proceedings of IEEE INFOCOM*, Tel Aviv, Israel, 2000; 404–413.
27. Khan M, Kumar V, Marathe M, Pandurangan G, Ravi S. Bi-criteria approximation algorithms for power-efficient and low-interference topology control in unreliable ad hoc networks, In *Proceedings of IEEE INFOCOM*, Rio de Janeiro, Brazil, 2009; 370–378.
28. Mehrjoo M, Awad M, Dianati M, Shen X. Design of fair weights for heterogeneous traffic scheduling in multichannel wireless networks. *IEEE Transactions on Communications* 2010; **58**(10): 2892–2902.
29. Chaudhry A, Hafez R, Aboul-Magd O, Mahmoud S. Throughput improvement in multi-radio multi-channel 802.11a-based wireless mesh networks, In *Proceedings of IEEE Global Telecommunications Conference (GLOBECOM)*, Miami, FL, USA, 2010; 1–5.
30. Shi Y, Hou Y. Optimal power control for multi-hop software defined radio networks, In *IEEE International Conference on Computer Communications*, Anchorage, AK, USA, 2007; 1694–1702, DOI: 10.1109/INFCOM.2007.198.
31. Shu T, Krunz M. Coordinated channel access in cognitive radio networks: a multi-level spectrum opportunity perspective, In *Proceedings of IEEE INFOCOM*, Rio de Janeiro, Brazil, 2009; 2976–2980.
32. Wu Y, Tsang D. Distributed power allocation algorithm for spectrum sharing cognitive radio networks with QoS guarantee, In *Proceedings of IEEE INFOCOM*, 2009; 981–989.
33. Lin YE, Liu KH, Hsieh HY. Design of power control protocols for spectrum sharing in cognitive radio networks: a game-theoretic perspective, In *Proceedings of IEEE International Conference on Communications (ICC)*, Cape Town, South Africa, 2010; 1–6.

34. Huang S, Liu X, Ding Z. Distributed power control for cognitive user access based on primary link control feedback, In *Proceedings of IEEE INFOCOM*, San Diego, CA, USA, 2010; 1–9.
35. Martignon F. Multi-channel power-controlled directional MAC for wireless mesh networks. *Wireless Communications and Mobile Computing* 2011; **11**(1): 90–107.
36. Wu SL, Tseng YC, Sheu JP. Intelligent medium access for mobile ad hoc networks with busy tones and power control. *IEEE Journal on Selected Areas in Communications (JSAC)* 2000; **18**(9): 1647–1657.
37. Haas Z, Deng J. Dual busy tone multiple access (DBTMA)-a multiple access control scheme for ad hoc networks. *IEEE Transactions on Communications* 2002; **50**(6): 975–985.
38. Cui H, Wei G, Zhang Z, Zhang J. Medium access control scheme supporting real-time traffic with power control in wireless ad hoc networks. *IET Communications* 2010; **4**(4): 377–383.
39. Nasipuri A, Das S. Multichannel CSMA with signal power-based channel selection for multihop wireless networks, In *Proceedings of IEEE Vehicular Technology Conference (VTC)-Fall*, Boston, MA, USA, 2000; 211–218.
40. So J, Vaidya NH. Multi-channel MAC for ad hoc networks: handling multi-channel hidden terminals using a single transceiver, In *Proceedings of ACM MobiHoc*, 2004; 222–233.
41. Zhang J, Zhou G, Huang C, Son S, Stankovic J. TMMAC: an energy efficient multi-channel MAC protocol for ad hoc networks, In *Proceedings of IEEE International Conference on Communications (ICC)*, 2007; 3554–3561.
42. Römer K. Time synchronization in ad hoc networks, In *Proceedings of the 2nd ACM International Symposium on Mobile Ad Hoc Networking & Computing (MobiHoc)*, Long Beach, California, USA, 2001; 173–182.
43. Choi B, Liang H, Shen X, Zhuang W. DCS: distributed asynchronous clock synchronization in delay tolerant networks. *IEEE Transactions on Parallel and Distributed Systems*. to appear.
44. Wu TY, Kuo KH, Cheng HP, Ding JW, Lee WT. Increasing the lifetime of ad hoc networks using hierarchical cluster-based power management. *KSII Transactions on Internet and Information Systems* 2011; **5**(1): 5–23.
45. Mo J, So HS, Walrand J. Comparison of multichannel MAC protocols. *IEEE Transactions on Mobile Computing (TMC)* 2008; **7**(1): 50–65.
46. Tang L, Sun Y, Gurewitz O, Johnson DB. EM-MAC: a dynamic multichannel energy-efficient MAC protocol for wireless sensor networks, In *Proceedings of ACM MobiHoc*, 2011.
47. Almotairi KH, Shen X. Fast and slow hopping MAC protocol for single-hop ad hoc wireless networks, In *Proceedings of IEEE International Conference on Communications (ICC)*, Kyoto, Japan, 2011; 1–5.
48. Xu K, Gerla M, Bae S. Effectiveness of RTS/CTS handshake in IEEE 802.11 based ad hoc networks. *Ad Hoc Networks* 2003; **1**(1): 107–123.
49. The Network Simulator ns-2. (Available from: <http://www.isi.edu/nsnam/ns> [Accessed on 1 July 2009]).
50. Zhang X, Gao Q, Zhang J, Wang G. Impact of transmit power on throughput performance in wireless ad hoc networks with variable rate control. *Computer Communications* 2008; **31**(15): 3638–3642.
51. Huang R, Zhai H, Zhang C, Fang Y. SAM-MAC: an efficient channel assignment scheme for multi-channel ad hoc networks. *Computer Networks* 2008; **52**(8): 1634–1646.
52. IEEE standard 80211a supplement. Wireless LAN medium access control (MAC) and physical layer (PHY) specifications. high-speed physical layer in the 5 GHz band July 1999.

AUTHORS' BIOGRAPHIES



Khaled H. Almotairi received his BSc degree from King Abdulaziz University, Jeddah, Saudi Arabia, in 2004 and his MSc and PhD degrees from the University of Waterloo, Waterloo, ON, Canada, in 2007 and 2012, respectively, all in Electrical and Computer Engineering. He is an assistant professor in the Department of Computer Engineering, at Umm Al-Qura University, Makkah, Saudi Arabia. From 2004 to 2005, he worked as a full-time instructor at the College of Telecommunication and Electronics, Jeddah, Saudi Arabia. His research interests include channel allocation, performance analysis and evaluation, protocol design, transmission power control, and ad hoc networking.



Xuemin (Sherman) Shen (IEEE M'97–SM'02–F09) received his BSc (1982) degree from Dalian Maritime University (China) and his MSc (1987) and PhD degrees (1990) from Rutgers University, New Jersey (USA), all in Electrical Engineering. He is a professor and the University Research Chair in the Department of Electrical and Computer Engineering, University of Waterloo, Canada. He was the Associate Chair for Graduate Studies from 2004 to

2008. Shen's research focuses on resource management in interconnected wireless/wired networks, wireless network security, wireless body area networks, and vehicular ad hoc and sensor networks. He was a co-author/editor of six books and has published more than 600 papers and book chapters in wireless communications and networks, control, and filtering. Shen served as the Technical Program Committee Chair for IEEE VTC'10 Fall, the Symposia Chair for IEEE ICC'10, the Tutorial Chair for IEEE VTC'11 Spring and IEEE ICC'08, the Technical Program Committee Chair for IEEE Globecom'07, the General Co-Chair for Chinacom'07 and QShine'06, and the Chair for IEEE Communications Society Technical Committee on Wireless Communications, and P2P Communications and Networking. He also serves/served as the Editor-in-Chief for IEEE Network, Peer-to-Peer Networking and Application, and IET Communications; a Founding Area Editor for IEEE Transactions on Wireless Communications; an Associate Editor for IEEE Transactions on Vehicular Technology, Computer

Networks, and ACM/Wireless Networks, and so on; and the Guest Editor for IEEE JSAC, IEEE Wireless Communications, IEEE Communications Magazine, ACM Mobile Networks and Applications, and so on. Shen received the Excellent Graduate Supervision Award in 2006 and the Outstanding Performance Award in 2004, 2007, and 2010 from the University of Waterloo; the Premier's Research Excellence Award (PREA) in 2003 from the Province of Ontario, Canada; and the Distinguished Performance Award in 2002 and 2007 from the Faculty of Engineering, University of Waterloo. Shen is a registered Professional Engineer of Ontario, Canada, an IEEE Fellow, an Engineering Institute of Canada Fellow, a Canadian Academy of Engineering Fellow, and a Distinguished Lecturer of IEEE Vehicular Technology Society and Communications Society.

Shen has been a guest professor of Tsinghua University, Shanghai Jiao Tong University, Zhejiang University, Beijing Jiao Tong University, Northeast University, and so on.