

A Comprehensive Survey of Knowledge-Driven Deep Learning for Intelligent Wireless Network Optimization in 6G

Ruijin Sun¹, Member, IEEE, Nan Cheng², Senior Member, IEEE, Changle Li³, Senior Member, IEEE, Wei Quan⁴, Senior Member, IEEE, Haibo Zhou⁵, Senior Member, IEEE, Ying Wang⁶, Member, IEEE, Wei Zhang⁷, Fellow, IEEE, and Xuemin Shen⁸, Fellow, IEEE

Abstract—The sixth generation (6G) wireless networks are envisioned to feature wide-area coverage, diversified full-scenario services, massive connections and dynamic heterogeneity, resulting in large-scale and complex network optimization problems. Traditional model-based methods, while effective in simple scenarios with precise mathematical models, struggle with high computational intensity and long processing times in the realistic and intricate applications of 6G. Pure data-driven deep learning (DL) methods offer powerful approximation capabilities and fast online inference but are hindered by insufficient datasets and poor interpretability. To address these issues, knowledge-driven DL integrates domain knowledge into neural networks, combining the strengths of both model-based and data-driven approaches. This survey systematically reviews knowledge-driven DL in wireless networks from a novel perspective of the knowledge integration approach. It provides a comprehensive definition of domain knowledge in wireless networks and clarifies the types of knowledge and their representations that can be integrated into neural networks. Furthermore, a leading taxonomy of knowledge integration approaches in wireless networks is proposed, encompassing the integration of domain knowledge into neural network model selection, neural network model customization, knowledge and data fusion architecture construction, loss function design, and hyperparameter configuration. Based on this taxonomy, literature on knowledge-driven resource allocation and signal processing is thoroughly reviewed. This

survey aims to provide an insightful guideline for effectively incorporating domain knowledge into neural networks in the field of wireless communications, ultimately advancing efficient and reliable intelligent 6G networks.

Index Terms—Domain knowledge, intelligent wireless networks, knowledge-driven DL, neural networks.

I. INTRODUCTION

6G is envisioned to constitute the foundational infrastructure for a fully intelligent, immersive, and sustainable digital world. It aims to deeply integrate communication, computation, sensing, and native intelligence to support seamless interactions between humans, machines, and environments in real time. Building on this vision, the International Telecommunication Union Radiocommunication sector (ITU-R) has released six pivotal usage scenarios for future 6G networks [1]. They consist of three evolutionary scenarios from the fifth-generation (5G) networks, i.e., immersive communication, massive communication, and hyper-reliable and low-latency communication, and three novel scenarios, i.e., ubiquitous connectivity, artificial intelligence (AI) and communication, and integrated sensing and communication. Accompanied by such sci-fi-like services, more rigorous performance metrics are required, including enhanced peak data rates, higher reliability, lower latency, extensive coverage, denser connectivity, and accurate positioning, among others [2], [3]. To meet these requirements, 6G networks are anticipated to flexibly manage multi-dimensional cloud-network resources, like computing, storage, spectrum, power and time, and innovatively propose cutting-edge signal processing technologies. Due to diversified services, tailored requirements, massively connected nodes and multi-dimensional resources, optimizing wireless networks in the 6G era can be remarkably complex, which poses great challenges for efficient optimization algorithm design. In the following subsections, three kinds of methods to tackle wireless network optimization problems are introduced.

A. Model-Based Theoretical Methods

In wireless communications, network optimization problems are dominated by model-based methods, wherein problems

Received 22 November 2024; revised 23 April 2025; accepted 26 May 2025. Date of publication 29 May 2025; date of current version 2 January 2026. This work was supported in part by the National Key Research and Development Program of China under Grant 2020YFB1807700, and in part by the National Natural Science Foundation of China (NSFC) under Grant 62201414. (Corresponding author: Nan Cheng.)

Ruijin Sun, Nan Cheng, and Changle Li are with the State Key Laboratory of Integrated Services Networks and the School of Telecommunications Engineering, Xidian University, Xi'an 710071, China (e-mail: sunruijin@xidian.edu.cn; nancheng@xidian.edu.cn; clli@mail.xidian.edu.cn).

Wei Quan is with the School of Electronic and Information Engineering, Beijing Jiaotong University, Beijing 100044, China (e-mail: weiquan@bjtu.edu.cn).

Haibo Zhou is with the School of Electronic Science and Engineering, Nanjing University, Nanjing 210023, China (e-mail: haibozhou@nju.edu.cn).

Ying Wang is with the State Key Laboratory of Networking and Switching Technology, Beijing University of Posts and Telecommunications, Beijing 100876, China (e-mail: wangling@bupt.edu.cn).

Wei Zhang is with the School of Electrical Engineering and Telecommunications, University of New South Wales, Sydney, NSW 2052, Australia (e-mail: w.zhang@unsw.edu.au).

Xuemin Shen is with the Department of Electrical and Computer Engineering, University of Waterloo, Waterloo, ON N2L 3G1, Canada (e-mail: sshen@uwaterloo.ca).

Digital Object Identifier 10.1109/COMST.2025.3574765

are modeled and algorithms are designed based on communication theory and mathematical principles, referred to as domain knowledge. With such domain knowledge summarized and validated by scientists and engineers over several decades, model-based methods are constructed by a series of explainable logic rules and mathematical formulas, making the network behavior understandable. As each step has a solid mathematical basis, the performance of model-based methods can be theoretically guaranteed, even in extreme environments. One typical example is the water-filling power allocation algorithm for the sum rate maximization in orthogonal frequency division multiplexing (OFDM) systems [4], which is solved by the Lagrangian multiplier method and has been proven to achieve the globally optimal solution. However, there exists a performance gap between theoretical design and practical application with model-based network optimization. Firstly, when addressing intricate wireless optimization problems, model-based methods often rely on simplified and idealized assumptions about communication systems [5], such as Gaussian noise and linear system behaviors. While these assumptions render the problems more manageable, they frequently lead to imprecise system models and consequently less than optimal solutions. Secondly, the iterative nature inherent in most model-based methods induces overwhelming computational complexity, particularly in the optimization of large-scale networks. As a result, the online processing time is considerably extended, making these methods fail to meet the stringent low-latency demands of time-sensitive services in 6G networks.

B. Data-Driven Deep Learning

Data-driven methods, represented by deep neural networks (DNNs) or deep learning (DL), hold significant promise in addressing the aforementioned challenges. In these methods, a neural network with numerous learnable weight parameters is constructed to establish a direct relationship between the network environment (such as channel state information) and optimal decisions (like power allocation), where these parameters are learned from massive labeled data. Compared with model-based methodologies, the advantages of data-driven approaches are manifold [6], [7]. Firstly, neural networks, due to their universal approximation capability, can capture complex relationships and dynamics that might be overlooked or oversimplified in theoretical models. This allows data-driven methods to efficiently address complex problems with inaccurate or unknown analytical models. Secondly, after the initial offline training phase, neural networks can provide rapid online predictions and decisions, essential for real-time applications in wireless networks. Achieving such a quick online processing speed is challenging for most theoretical methods, although model-based iterative algorithms are thoroughly understood. Owing to these strengths, data-driven methods have been investigated and overviewed in wireless communications, ranging from channel state information feedback [8] and wireless physical layer design [9], [10] to wireless link quality estimation [11] and efficient resource management [12], [13].

While offering notable benefits, the direct application of pure data-driven DL to 6G wireless network optimization remains challenging. Firstly, the intricate and dynamic nature of wireless resource management involves multiple constraints, such as power limits, latency requirements, and interference control, that are difficult to handle via conventional neural networks. Secondly, the efficacy of neural networks highly relies on the large volume of high-quality data. Acquiring such datasets from real-world wireless network environments is often time-consuming or even infeasible due to privacy concerns and labeling costs. Thirdly, data-driven DL models often operate as “closed boxes,” lacking interpretability and performance guarantees, which severely limits their applicability in safety-critical wireless scenarios like connected autonomous driving. These limitations expose the shortcomings of current DL paradigms in 6G networks and highlight the need to rethink how learning can be enhanced under domain-specific constraints.

C. Knowledge-Driven Deep Learning and Related Work

To address these issues, a new paradigm is developed to incorporate domain knowledge, the foundation of model-based theoretical methods, into data-driven neural networks to benefit from both approaches. This novel method is henceforth called knowledge-driven DL, which constructs neural networks with the guidance of communication-specific domain knowledge garnered over decades, such as models, algorithms and unique features of wireless networks. A typical example is the sum-rate maximization problem in a large-scale device-to-device (D2D) network, where knowledge of the graph-structured topology motivates the use of graph neural networks (GNNs), and knowledge of the weighted minimum mean-square error (WMMSE) algorithm is also embedded via algorithm unfolding, resulting in a knowledge-driven customized GNN model named WUGNN [14]. By preserving the iterative structure of WMMSE, WUGNN not only enables parameter learning from data, but also inherits interpretability¹ from the algorithmic design [17]. As shown in Fig. 1, WUGNN achieves superior sum-rate performance and millisecond-level inference latency, demonstrating both scalability and real-time efficiency compared with model-based and data-driven baselines. Besides, the number of required training samples and learnable parameters are also significantly reduced [18].

Due to its potential advantages, knowledge-driven deep learning (DL) has received considerable attention across multiple fields. In natural language processing (NLP) and computer vision (CV), von Rueden et al. [19] proposed a systematic framework for knowledge-driven DL, encompassing knowledge sources, representations, and integration strategies. In physics, Meng et al. [20] introduced the concept of physics-informed DL and reviewed knowledge integration approaches tailored to physical systems. In the context of

¹Unlike post-hoc explainability that interprets neural network models after training, knowledge-driven DL belongs to ante-hoc explainability paradigm, also referred to as intrinsic explainability, where interpretability is embedded during model design or learning process [15], [16]. By enabling models to be transparent and interpretable from the start, ante-hoc explainability is particularly crucial in wireless networks with safety-critical requirements.

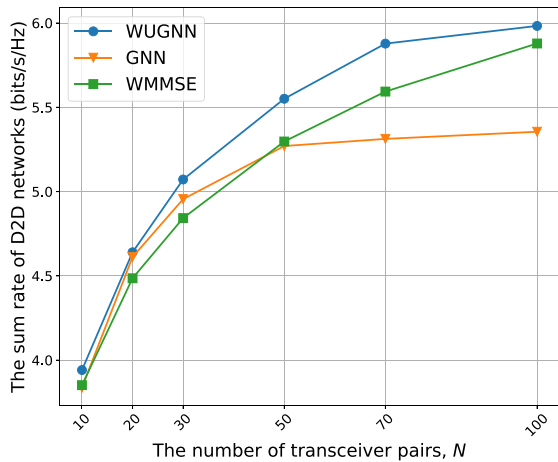

(a) The scalability comparison of the proposed knowledge-driven WUGNN and the other two approaches.

N	10	20	30	50	70	100
WUGNN	0.018	0.021	0.022	0.021	0.025	0.040
GNN	0.008	0.010	0.010	0.009	0.016	0.021
WMMSE	4.262	20.239	41.328	114.669	188.005	384.590

(b) The online inference time of three approaches

Fig. 1. Performance evaluation of a knowledge-driven deep learning example in wireless network optimization.

wireless networks, several related surveys have emerged. For instance, She et al. [21] reviewed ultra-reliable low-latency communication from the perspective of DL training methodologies, mentioning the potential of incorporating domain knowledge without further structural analysis. Shi et al. [22] surveyed DL for large-scale wireless optimization, where knowledge-driven neural models are briefly introduced from the perspective of optimization methods. A more relevant attempt by Shlezinger et al. [23] categorized knowledge-driven signal processing methods into model-aided and DNN-aided DL. However, this division is conceptually ambiguous due to the intertwined roles of data and models.

Based on a comprehensive review (summarized in Table I), we observe that no existing survey has explicitly defined communication-specific domain knowledge, nor clarified what types of such knowledge can be embedded into neural networks for wireless network optimization. While some customized neural architectures have been discussed individually, a unified and systematic taxonomy of knowledge integration approaches for wireless network optimization is still lacking. Knowledge integration taxonomies proposed in other fields, such as NLP & CV [19] and physics [20], can offer valuable insights, but often struggle to address stringent physical communication constraints and embed rich model-based methods inherent in wireless communications into neural networks. This critical gap hinders researchers' ability to develop knowledge-driven DL models suited to the demands of intelligent 6G networks.

D. Our Contributions

Motivated by these observations, this survey provides a comprehensive review of knowledge-driven deep learning

specifically tailored to wireless network optimization. It systematically defines communication-specific domain knowledge, categorizes its types and representations, and proposes a unified taxonomy of knowledge integration approaches. Guided by this taxonomy, typical examples and representative literature in resource management and signal processing for each knowledge integration approach are thoroughly analyzed, highlighting how domain knowledge can be effectively embedded into neural networks to enhance interpretability, generalization, and performance in wireless networks. Our main contributions are threefold.

- Firstly, inspired by the philosophical definition of knowledge, a creative definition of communication-specific domain knowledge is given. This knowledge is broadly divided into scientific and expert knowledge, with each category presenting principal knowledge types and corresponding representations.
- Secondly, we propose a novel taxonomy of knowledge integration approaches in wireless networks, based on which components of the deep learning pipeline the domain knowledge is integrated into and how it is integrated into these components. This taxonomy covers the integration of domain knowledge for neural network model selection, neural network model customization, knowledge and data fusion architecture construction, loss function design, and hyperparameter configuration, which offers a concrete guideline for the integration of knowledge and neural networks.
- Thirdly, following the proposed taxonomy, the concept of each knowledge integration approach is presented as well as a typical example to illustrate how communication-specific domain knowledge is integrated into neural networks. Moreover, the literature on knowledge-driven resource allocation and signal processing is reviewed. Furthermore, several challenges and future directions are discussed.

By clarifying what domain knowledge can be integrated into neural networks and how, this survey aims to provide fundamental principles or guidelines for designing knowledge-driven wireless networks that fully leverage domain-specific knowledge and advanced DL techniques. We hope that this survey will facilitate future research in this evolving field, ultimately leading to the development of more efficient, reliable, and interpretable wireless communication systems. Table II lists the main acronyms of this survey.

As shown in Fig. 2, the remainder of this survey is organized as follows. Section II gives a concept and taxonomy of knowledge in wireless networks. Then, Section III describes the concept of knowledge-driven DL and proposes a novel taxonomy of knowledge integration approaches. Following this taxonomy, Sections IV–VIII respectively provide a detailed classification of each knowledge integration approach. In each classification, the concept and a typical example of the knowledge integration approach are given, as well as relevant literature on wireless resource management and signal processing. Finally, Section IX presents the future directions of knowledge-driven DL and Section X concludes this survey.

TABLE I
LISTS OF SURVEY PAPERS ON KNOWLEDGE-DRIVEN DL

Survey	Application field	Main topics	Relevance to knowledge-driven DL	Domain knowledge definition	Domain knowledge classification	Knowledge-driven DL taxonomy	Knowledge integration taxonomy guided review
[8]–[13]	Wireless networks	DL for wireless networks.	No				
[19]	NLP and CV	A taxonomy of knowledge-driven DL in NLP and CV.	High	✓	✓	✓	
[20]	Physics	Physics-informed DL.	High		✓	✓	✓
[21]	Wireless networks	DL for resource management in ultra-reliable and low latency communications.	Low				
[22]	Wireless networks	DL for large-scale wireless network optimization.	Low				
[23]	Signal processing	Knowledge-driven signal processing in wireless communication and image processing.	High			✓	✓
Our work	Wireless networks	Knowledge-driven intelligent wireless network optimization.	High	✓	✓	✓	✓

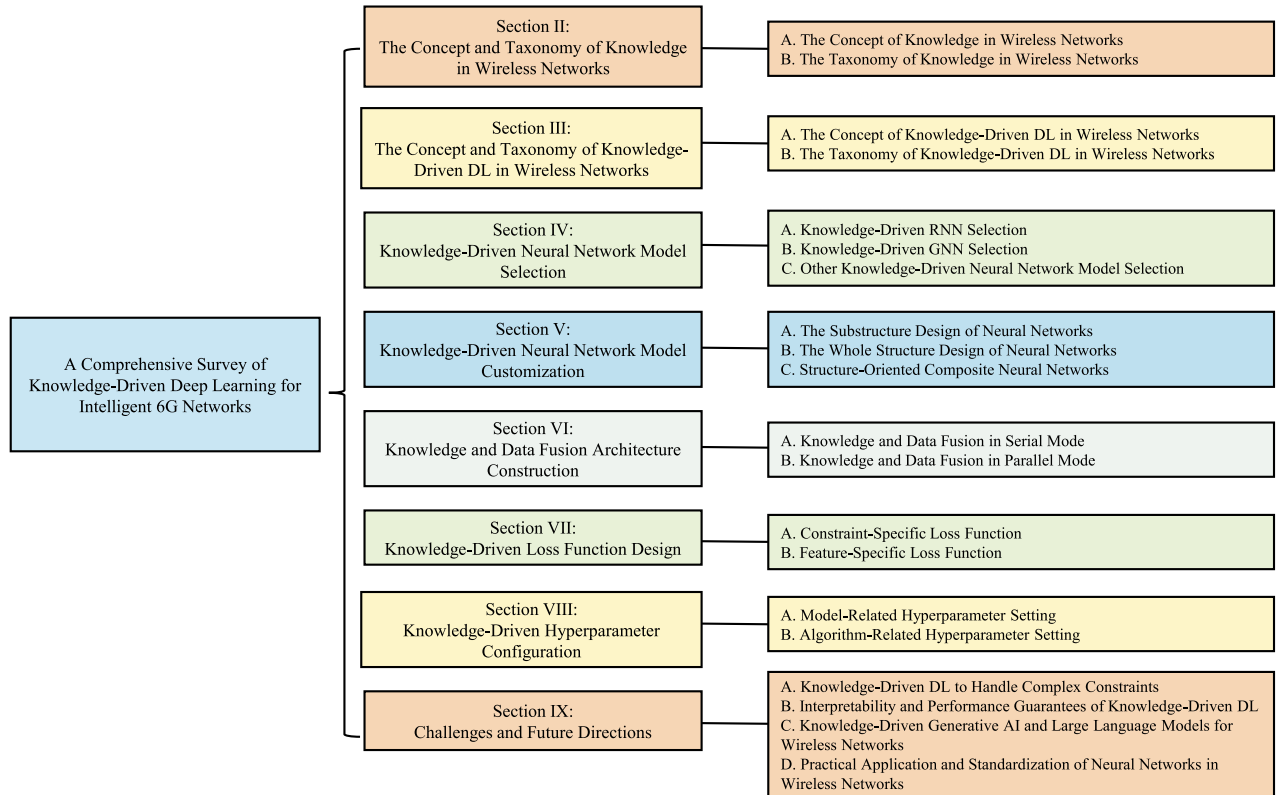

Fig. 2. Road map of this survey.

II. THE CONCEPT AND TAXONOMY OF KNOWLEDGE IN WIRELESS NETWORKS

In this section, we initiate by establishing a clear definition of knowledge in the realm of wireless networks. Subsequently, we classify this communication-specific domain knowledge into two broad categories, i.e., scientific knowledge and expert knowledge. In each category, more specific knowledge types are presented in detail, as well as their respective representations and typical examples.

A. The Concept of Knowledge in Wireless Networks

Knowledge is the cognition and summary of the human exploration results about the physical world and the mental world, which is discovered from the real world and then used as principles to improve the world. Due to its abstract and generalization nature, it is not easy to define knowledge uniformly and accurately. In the field of philosophical epistemology, the concept of knowledge is the primary subject and is still a controversial issue. One classic definition comes from Plato,

TABLE II
LIST OF MAIN ACRONYMS

Acronyms	Definition
3GPP	3rd generation partnership project
5G	Fifth generation
6G	Sixth generation
ADMM	Alternating direction method of multipliers
AI	Artificial intelligence
AM	Alternative minimization
AMP	Approximate message passing
BS	Base station
CNN	Convolutional neural network
CSI	Channel state information
CV	Computer vision
D2D	Device-to-device
DL	Deep learning
DNN	Deep neural network
DRL	Deep reinforcement learning
FDD	Frequency-division duplexing
GNN	Graph neural network
IoT	Internet of Things
IRS	Intelligent reflecting surface
ISI	Inter-symbol interference
ISTA	Iterative shrinkage thresholding algorithm
ITU-R	International Telecommunication Union Radiocommunication
LLM	Large language model
LS	Least square
LSTM	Long short-term memory
MAP	Maximum a posterior
MIMO	Multi-input multi-output
MISO	Multi-input single-output
ML	Maximum likelihood
MP	Message passing
MPGNN	Message passing GNN
MU	Multiuser
NAIE	Network AI engine
NLP	Natural language processing
OAMP	Orthogonal approximate message passing
OFDM	Orthogonal frequency division multiplexing
PE	Permutation equivalence
PGD	Projected gradient descent
QoS	Quality of service
QSI	Queue state information
RAN	Radio access network
RNN	Recurrent neural network
SCA	Successive convex approximation
SDR	Semi-definite relaxation
SIC	Soft interference cancellation
SINR	Signal to interference plus noise ratio
SNR	Signal to noise ratio
TCP	Transmission control protocol
UAV	Uncrewed aerial vehicle
VNF-FG	Virtual network function forwarding graph
WMMSE	Weighted minimum mean-square error
ZF	Zero-forcing

i.e., to qualify as knowledge, a statement must meet three criteria: it must be justified, true, and believed [24]. Furthermore, Michael Polanyi classified human knowledge into explicit and implicit knowledge [25]. The former is expressed in written words, diagrams, and mathematical formulas; the latter is not expressed, like the knowledge in the act of doing something. A more universal concept of knowledge is the cognition and experience accumulation gathered by individuals through practical activities aimed at changing the objective world. It includes understanding the essence, properties, and states of things as well as methods for solving problems.

In the field of AI, researchers devote themselves to making computers understand, acquire, process and infer knowledge like human beings. Towards this end, knowledge-based engineering is proposed, of which expert systems consisting of

the knowledge repository and the inference engine are built to imitate the reasoning ability of humans. In this circumstance, knowledge usually describes the relationships between entities in certain contexts, which is obtained via the analysis of sets of information [26]. For the formalization, knowledge is mainly represented by knowledge graphs with the structured triplet form of “entity-relational-entity” [27]. Due to their powerful semantic processing ability, knowledge graphs have been widely adopted in intelligent search, intelligent question answering, recommendation systems and decision-making.

Different from knowledge in the field of AI describing relationships between entities, knowledge in wireless networks is more specialized and diversified. With a century’s exploration, a large number of theoretical laws and practical experiences have been discovered and justified in this field, which lays the foundation for the rapid development of ubiquitous cellular networks, satellite communication networks as well as ad-hoc networks. This kind of knowledge has been and will continue to be applied in wireless communication networks to extract the network feature and then guide the network optimization, including both the resource management and the signal processing. In this survey, borrowing from the philosophical definition of knowledge, we try to give a concept of knowledge in the field of wireless communication networks as follows.

Definition 1: Communication-specific domain knowledge is technical theories and experiential cognition accumulated by scientists and experts in the process of conceiving, constructing, and optimizing wireless communication networks.

In general, communication-specific domain knowledge involves two key aspects. During the modeling process, knowledge is the cognitive description of attributes, relationships, and the evolving laws of the network environment, user entities, and service requirements. Examples include modeling theories of wireless tasks like Markov decision processing, and unique features of wireless networks like the spatial correlation of wireless channels. During the decision-making process, knowledge is the cognitive summarization of the principles, algorithms, and theories applied in problem-solving during the decision-making process. Examples include model-based theoretical algorithms or solutions for wireless tasks like zero-forcing precoding. Such knowledge can be employed to inform the design of neural networks for wireless optimization problems. For a detailed understanding of this communication-specific domain knowledge, the following subsection presents a summary of the taxonomy, including knowledge classification and knowledge representation.

B. The Taxonomy of Knowledge in Wireless Networks

To figure out what exactly communication-specific domain knowledge consists of, as illustrated in Fig. 3, we broadly classify knowledge into two categories, namely, scientific knowledge and expert knowledge, which range from more formal to less formal, or from explicitly validated to implicitly validated. Indeed, expert and scientific knowledge are somehow interrelated, as the former can be formalized through rigorous validation, while the latter often informs

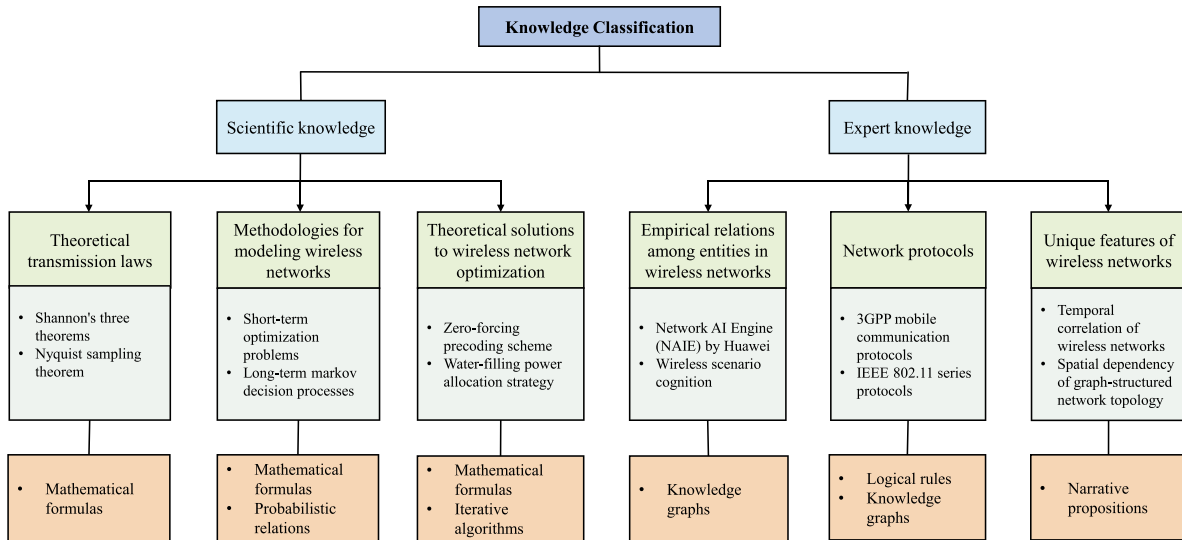

Fig. 3. The taxonomy of knowledge in wireless networks, including knowledge classification, knowledge representation and typical examples.

real-world engineering experience. This classification aims not to divide them rigidly, but to distinguish their distinct foundational basis, representational forms and functional roles in knowledge-driven DL for wireless networks. Building on this categorization, we further summarize the principal types of knowledge within each category in this subsection. As knowledge representation would decide the ease and approaches of knowledge integration in neural networks, we also provide detailed descriptions of the corresponding representations for each type of knowledge, along with illustrative examples to enhance clarity and comprehension.

1) *Scientific Knowledge*: Scientific knowledge aims to establish universal laws that can theoretically explain the operation mechanism of wireless networks, which is discovered and demonstrated via rigorous scientific experiments or mathematical reasoning. It is systematic and objective, and widely accepted by the communication community. Typically, scientific knowledge is explicitly represented in structured and formal mathematical expressions, including formulas, algorithms and probabilistic relations. In wireless communication networks, scientific knowledge consists of theoretical transmission laws, methodologies for modeling wireless networks and theoretical solutions to wireless network optimization.

Theoretical Transmission Laws. Theoretical transmission laws lay the foundation for wireless communications, which are also the driving force for the continuous flourishing of wireless networks. Thanks to the exploration of pioneering researchers, a systematic theoretical basis in wireless communication networks has been constructed, consisting of signals and systems, digital signal processing, principles of wireless communications, information theory, and more. Building on these foundations, a standard physical link can be established between a transceiver pair, including channel encoding and decoding, modulation and demodulation, multi-input multi-output (MIMO) precoding and receiver, and channel estimation. In terms of representations, knowledge concerning theoretical transmission laws is explicitly articulated in strict and formal mathematical formulas, which

are either equalities or inequalities to scalars, vectors, and matrices. Typical examples of theoretical transmission laws are Shannon's three theorems and Nyquist sampling theorem, where the most renowned formula is the channel capacity with infinite block length, denoted as $C = \log(1 + S/N)$, with C , S , and N respectively being the channel capacity, the signal power, and the noise power.

Methodologies for Modeling Wireless Networks. To effectively tackle practical problems encountered in wireless communication networks, the primary task is to analyze and abstract these problems as appropriate mathematical problems, adopting mathematical language, concepts and symbols. Such knowledge about extracting essential contradictions from complex real-world wireless networks and describing them as suitable mathematical problems are referred to as methodology for modeling wireless networks. Generally, practical problems in wireless networks are modeled by mathematical theories, such as probability and mathematical statistics, stochastic process, optimization theory, game theory, graph theory and so on. Apart from abstracting practical problems, modeling methodologies also help to build simulation platforms or digital twins of wireless networks to simulate their operation of wireless networks. During the modeling of wireless network optimization problems, a series of related mathematical formulas or probabilistic relations are derived based on corresponding mathematical theories. For example, short-time resource management or signal processing problems with diversified quality of service (QoS) requirements are modeled as optimization problems represented by mathematical formulas, and long-term network behaviors, such as queue management problems are modeled as Markov decision processes represented by probabilistic relations.

Theoretical Solutions to Wireless Network Optimization. With mathematically modeled wireless network optimization problems, the subsequent procedure is to derive effective theoretical solutions. These are also usually achieved according to mathematical theories, such as deterministic optimization, stochastic optimization, game theory and so

on. The scientific knowledge that describes such mathematical manipulations from network status (inputs) to decision results (outputs) is known as theoretical solutions to wireless network optimization. As with strict mathematical derivations in each step, theoretical solutions are interpretable and can provide performance guarantees for wireless network optimization, contributing to understanding the behavior of wireless networks. Through decades of efforts, a plethora of theoretical solutions have been accumulated for diversified network optimization problems, including system-level resource management and link-level transmission strategy. Typically, these theoretical solutions are represented by mathematical formulas and iterative algorithms [28], which are respectively for simple problems with analytical solutions and complex problems. Famous examples are the zero-forcing (ZF) precoding scheme for MIMO transmission expressed as formulas and the water-filling power allocation strategy for OFDM systems expressed as iterative algorithms.

2) *Expert Knowledge*: Expert knowledge refers to practical experience or intuition, summarized and validated by specialists or engineers in the field of wireless communication networks. It is contextual and subjective, and often specific to an individual's experiences, perspectives and interpretations. Although without theoretical verification, expert knowledge is highly valuable for solving complex real-world problems in wireless networks that require nuanced understanding and decision-making. Compared with scientific knowledge, expert knowledge is not easy to articulate and is usually represented in relatively informal expressions. In wireless communication networks, expert knowledge includes empirical relations among entities in wireless networks, network protocols, and unique features of wireless networks.

Empirical Relations Among Entities in Wireless Networks. Empirical relations among entities in wireless networks refer to the observed and established relationships or patterns that exist between various components or entities within wireless networks. Here, network entities can include network infrastructure elements (like base stations and core network functions), network users (like mobile devices and sensor nodes), performance metrics (like rate and latency) and so on, varying with analyzed problems. Then, relations among these entities are derived from real-world experience and semi-structured maintenance logs rather than theoretical or mathematical models, which are crucial for understanding how various network components affect each other in actual operational environments. Generally, this relational knowledge is represented by a structured knowledge graph $\mathcal{G} = \{\mathcal{V}, \mathcal{E}\}$, where vertices \mathcal{V} and edges \mathcal{E} respectively denote entities and relations among these entities. The most famous application of this empirical relational knowledge in wireless networks is intelligent network operation and maintenance. In this domain, a knowledge graph is constructed to map out relationships among network elements, network configurations, performance metrics and alarm indicators for effectively handling network failure with knowledge reasoning. A specific case of such an application is the network AI engine (NAIE) developed by Huawei, which employs telecom knowledge graphs to empower automatic driving

networks [29]. Furthermore, relational knowledge is highly valuable in wireless scenario recognition. In this context, a knowledge graph is created, encompassing elements such as the network environment, network users, and service requirements to accurately recognize and classify different scenarios with personalized demands. It is pivotal in adapting network responses and strategies to align with the characteristics and specific demands of each identified scenario, leading to optimized network performance and enhanced user experiences.

Network Protocols. In wireless communication networks, network protocols are a set of standardized rules and guidelines that govern the transmission and reception of data over wireless networks, which usually tailors to accommodate the unique characteristics of wireless mediums, such as fast channel fading and user mobility. They define how data is formatted, transmitted, and processed over the network, involving both the theoretical techniques created by researchers and the practical experiences of engineers. As network protocols ensure interoperability, reliability, and efficiency in communication, devices in a wireless network can communicate seamlessly, regardless of disparities in design, manufacture, or internal configuration. In terms of representations, network protocols can be expressed as logical rules, such as flowcharts or state diagrams, illustrating how data moves through various stages of processing or how the system transitions between different states in response to certain events. Alternatively, they can also be abstracted as knowledge graphs to depict intricate relationships among various protocol components. Prominent examples of wireless network protocols include the 3rd generation partnership project (3GPP) mobile communication protocols, such as the 5G standards, and IEEE 802.11 series protocols like WiFi standards. In practical wireless networks, all network optimization designs should adhere to the corresponding network protocols to guarantee interoperability among different devices.

Unique Features of Wireless Networks. Unique features of wireless networks refer to characteristics or patterns that are straightforwardly discovered through keen observations, simple data analysis, and a deeper understanding of the network's behavior and dynamics. These features represent the inherent and crucial aspects of network behaviors and are instrumental in enhancing the optimization of wireless networks. As the captured network behaviors are often non-quantifiable, unique features of wireless networks are best articulated by narrative propositions. This form of representation, while perhaps less formal compared with mathematical expressions, provides a clearer and more comprehensible insight into the network's dynamics. Notable among these unique features are the temporal correlation patterns found in wireless traffic, which are crucial for predicting network load, managing bandwidth allocation, and ensuring consistent quality of service across different times and conditions. Another significant feature is the graph-structured nature of wireless network topology, which is vital for optimizing network coverage, minimizing interference, and enhancing overall network resilience and performance.

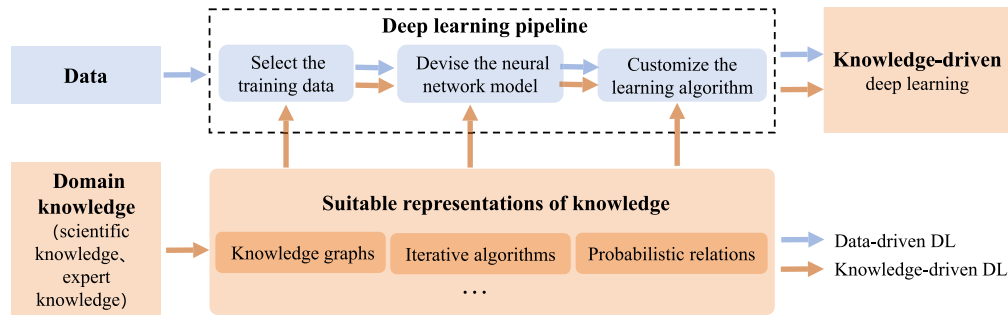

Fig. 4. The pipeline of knowledge-driven DL. Compared with data-driven DL, knowledge-driven DL incorporates domain knowledge with suitable representations into neural networks to select the training data, devise the neural network model, and customize the learning algorithm.

III. THE CONCEPT AND TAXONOMY OF KNOWLEDGE-DRIVEN DL IN WIRELESS NETWORKS

With the definition of communication-specific domain knowledge, in this section, we initially introduce the concept of knowledge-driven DL in wireless communication networks. Subsequently, based on a review of existing literature, we present a comprehensive taxonomy of knowledge-driven DL, specifically focusing on knowledge integration approaches.

A. The Concept of Knowledge-Driven DL in Wireless Networks

In wireless communication networks, the widely adopted methodology for applying knowledge in network optimization is the model-based theoretical approach, which initially models real-world problems with validated communication theories and then addresses these problems using explainable mathematical theories like convex optimization and game theory. Although with superior interpretability and theoretical performance guarantee, the model-based approach fails to effectively handle large-scale complicated network optimization problems in the forthcoming 6G, owing to its inaccurate modeling of complex relationships and long online operation time. These challenges can be potentially tackled by data-driven DL approaches, which statistically learn the network optimization strategies from data via neural networks with powerful universal approximation ability. Once the neural network is well-trained offline, network optimization strategies in different parameter configurations can be quickly inferred, resulting in a fast online response speed. However, the “closed-box” nature of neural networks with poor interpretability prevents their widespread application in wireless communication networks.

To address the issues encountered by data-driven DL approaches, a novel paradigm adopting knowledge for intelligent wireless network optimization, called knowledge-driven DL, is gaining traction. This approach explicitly incorporates comprehensible prior knowledge to guide the construction and training of neural networks. The involved prior knowledge in wireless communication networks, also termed communication-specific domain knowledge, is distilled from the unique attributes of network optimization issues and formed in various representations, which has been summarized in the previous Section III. A typical knowledge-driven DL

pipeline consists of four main components, i.e., the training data, the neural network model, the learning algorithm and domain knowledge, as illustrated in Fig. 4. Compared with pure data-driven DL, additional domain knowledge is added to the pipeline, which is represented in various forms, such as knowledge graphs, iterative algorithms, probabilistic relations and so on. When applying the knowledge-driven DL approach, network optimization problems are first formulated as regression tasks, where the network status (inputs) is mapped to optimization strategies (outputs) via neural networks. Then, external domain knowledge is involved in selecting the training data, devising the neural network model and customizing the learning algorithm.

Definition 2: Knowledge-driven deep learning in wireless networks refers to the deep learning method where additional communication-specific domain knowledge is explicitly integrated to enhance the insufficient training data and to guide the design of the neural network model and the learning algorithms. Such integrated knowledge stems from the cognitive description, analysis and summary of specific problems in wireless communication networks, independent of the original labeled training data, which is represented in the form of mathematical formulas, theoretical algorithms/rules and knowledge graphs, etc.

By explicitly incorporating domain knowledge with appropriate formal representations into all components of the DL process, the knowledge-driven DL approach has the strengths of both the model-based theoretical approach and the data-driven DL approach. Firstly, the interpretability of knowledge-driven DL is greatly improved, resulting in a reduction in learnable parameters, a decrease in required training data samples, and a lessening of the offline computational load. Secondly, as opposed to model-based theoretical approaches that are heavily reliant on precise modeling, the domain knowledge employed in knowledge-driven DL merely provides a fundamental and generic characteristic of the task. Any performance decline due to model inaccuracies is offset by the universal approximation capabilities of DL. Thirdly, knowledge-driven DL methods retain the rapid online inference capabilities of neural networks, enabling them to satisfy the demanding low-latency requirement of real-time services in dynamic networks. Owing to these strengths listed above, knowledge-driven DL is appealing in 6G networks [30], [31].

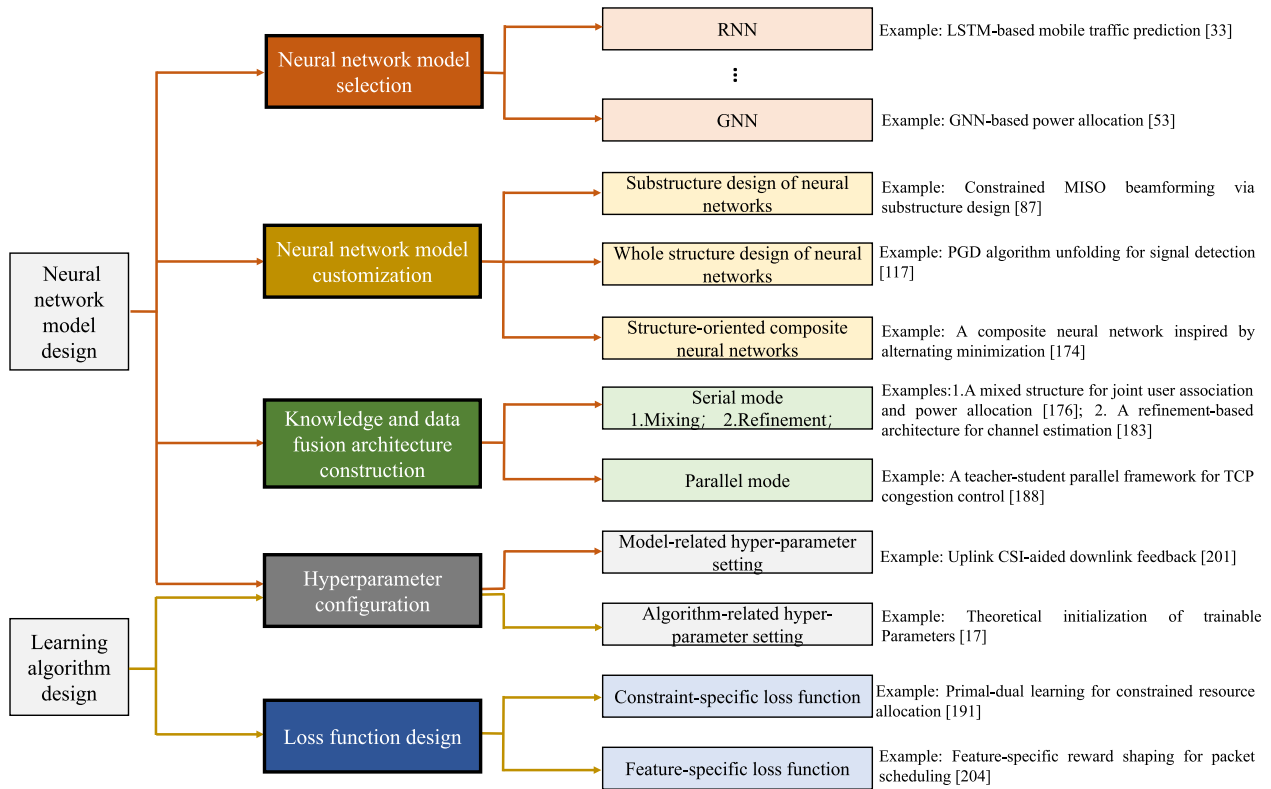

Fig. 5. The taxonomy of knowledge-driven DL in wireless networks. This novel taxonomy tailored to wireless network optimization is first proposed through a comparative and iterative literature survey. It offers a structured framework for categorizing knowledge integration approaches and serves as a guideline for the principled design of knowledge-driven intelligent wireless networks.

B. The Taxonomy of Knowledge-Driven DL in Wireless Networks

In knowledge-driven intelligent wireless networks, beyond identifying what domain knowledge to incorporate, a core question is how to effectively embed such knowledge into neural networks. This survey provides a structured taxonomy of knowledge integration approaches, illustrated in Fig. 5, which is constructed based on which components of the DL pipeline domain knowledge is integrated into, and how such integration is achieved. Specifically, the taxonomy aligns with two key components of the DL workflow, i.e., the neural network model, which determines the learning capacity, and the learning algorithm, which directs the learning process. Within the model component, domain knowledge can be incorporated through model selection, model customization, the construction of knowledge–data fusion architectures and model-related hyperparameter configuration. On the algorithm side, domain knowledge can be embedded via algorithm-related hyperparameter setting and loss function design. Combining the two hyperparameter setting schemes, the proposed taxonomy of knowledge-driven DL in Fig. 5 integrates domain knowledge into neural networks through neural network model selection, neural network model customization, knowledge and data fusion architecture construction, loss function design, and hyperparameter configuration.

This taxonomy is developed through a broad and iterative review of recent literature in wireless network optimization and captures the prevailing approaches by which domain

knowledge has been systematically embedded into DL. It provides a unified framework for understanding how domain knowledge can be systematically integrated into deep learning. Besides, the modular organization of the taxonomy allows each integration approach to be applied or adapted independently, facilitating its extension to future techniques and cross-domain applicability. By organizing existing work into this structured framework, the taxonomy not only reflects the current landscape of knowledge-driven DL in wireless networks but also serves as a foundation for the principled design of knowledge-driven intelligent wireless networks.

In the following sections, we explore the detailed concepts of each knowledge integration approach, providing typical examples to illustrate how domain knowledge is integrated into neural networks in wireless networks. For each approach, we also offer a comprehensive review of the relevant literature, highlighting the involved domain knowledge and specific knowledge integration approaches that have been proposed in the field. This review will focus particularly on knowledge-driven resource management and signal processing, two fundamental areas in wireless networks where deep learning has been extensively utilized.

IV. KNOWLEDGE-DRIVEN NEURAL NETWORK MODEL SELECTION

Knowledge-driven neural network model selection, as depicted in Fig. 6, employs domain knowledge to choose a suitable neural network from a variety of existing ones,

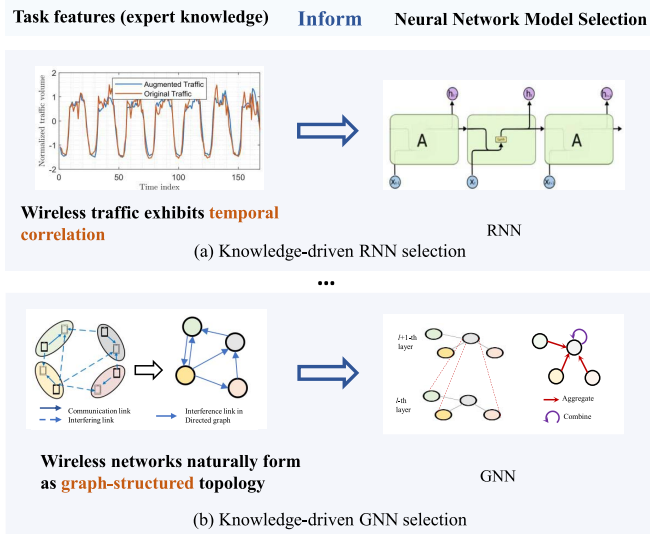

Fig. 6. The knowledge-driven neural network model selection.

such as recurrent neural networks (RNNs), convolutional neural networks (CNNs) and GNNs. Each of these models is particularly suited to tasks with specific characteristics, such as temporal dependencies or graph-based relationships. Among them, multi-layer perception (MLP) is often treated as a general-purpose baseline without explicit prior knowledge. By aligning the model structure with task characteristics through domain knowledge, this selection process can lead to improved inference performance, enhanced interpretability, and better scalability [32]. In wireless networks, such knowledge mainly belongs to unique features of wireless networks in expert knowledge and stems from an in-depth understanding and empirical recognition of tasks, which is portrayed by narrative propositions. According to the literature review, wireless network features, like the widespread temporal correlation and graph-structured network topology, are involved in wireless tasks to respectively inform the appealing RNN and GNN models. In the following, the concept of knowledge-driven RNN and CNN selection is respectively explored, along with detailed examples provided for each. Additionally, the relevant literature on knowledge-driven wireless resource management and signal processing is reviewed and the involved knowledge and knowledge integration approach are summarized in Table III.

A. Knowledge-Driven RNN Selection

1) *Concept*: Knowledge-driven RNN selection refers to employing domain knowledge regarding temporal correlations presented in wireless networks to select RNNs as the right model. In wireless networks, aspects like network traffic, available spectrum, and wireless channel environments change over time but exhibit intricate temporal dependencies. Due to excelling in learning long-term temporal dependencies from sequence data via cell states and control gates, RNNs, especially long short-term memory (LSTM) networks, have become attractive choices for tasks involving long-term temporal correlations to enhance performance and efficiency.

2) *Typical Example*: Consider an LSTM-based mobile traffic prediction as an example. In wireless networks, mobile traffic patterns gradually fluctuate over time, exhibiting strong temporal correlation. By separating each time step as a sequential point, mobile traffic data becomes a correlated time series. Inspired by knowledge of such temporal correlation, as illustrated in Fig. 6(a), RNN, especially LSTM, is selected as the most suitable neural network model for predicting future mobile traffic based on historical data [33]. With its cell states and control gates, LSTM can effectively capture long-term dependencies in the data, enabling accurate predictions over extended periods. As demonstrated in [33], a modified LSTM with sparsely connected neurons lowers computational costs while maintaining prediction accuracy.

3) *Related Literature Review on Wireless Resource Management*: In intelligent wireless resource management, tasks such as traffic prediction and long-term resource allocation often exhibit strong temporal correlations due to the dynamic nature of wireless networks. To effectively address these tasks, models must capture the evolving patterns over time to achieve accurate predictions and efficient resource allocation. LSTM, known for its ability to handle sequential data and long-term dependencies, is an ideal choice for managing these time-varying tasks.

With the ability to capture the temporal dependency, LSTM-based wireless traffic prediction has been widely investigated, which assists in proactively allocating the required resources. For the prediction of the overall traffic in telecommunication networks, a modified LSTM with stochastic connected neurons is proposed in [33], which is of sparse property to a certain degree and reduces the computing cost without sacrificing the prediction accuracy. To reduce the required training samples, a meta-learning framework with LSTM for mobile traffic prediction in wireless networks is also devised [34]. Then, the per-user traffic prediction is conducted via LSTM to dynamically adjust the parameters of the discontinuous reception scheme [35]. Besides, the traffic prediction for specific services is also investigated. In [36], the LSTM-based voice traffic prediction is proposed and validated on a real-world dataset, which exhibits better accuracy on base stations' Erlang. In [37], the traffic of machine-type devices is predicted via LSTM to adaptively configure the wake-up signal technology for energy saving.

Another popular application of LSTMs in wireless communication networks is long-term resource management. To minimize the average age of information in ad hoc networks, the user scheduling problem in [38] is transformed as a time-series classification problem and tackled by the bidirectional LSTM to deal with the time-varying network state. To improve the network throughput in multi-channel HetNets with different access control protocols, a novel deep reinforcement learning (DRL)-based access policy is proposed [39], where the underlying temporal correlation of spectrum states is exploited via LSTM to predict the spectrum utility. For the computing offloading, the computing offloading and resource allocation problem in Fog networks is formulated as a partially observable Markov decision problem and solved by the deep recurrent Q-network [40], where the LSTM is to

TABLE III
KNOWLEDGE-DRIVEN NEURAL NETWORK MODEL SELECTION

Specific integration approach	Areas in wireless networks	Applications	Specific integrated knowledge	Specific knowledge integration approach
knowledge-driven RNN selection	Resource management	Wireless traffic prediction [33]–[37]	Wireless network traffic exhibits strong temporal dependency.	RNN, especially LSTM, is selected as basic neural network model.
		Long-term resource management problems [38]–[43]	The time-varying network state introduces temporal correlation.	
	Signal processing	Signal detection with ISI [44]–[48]	The ISI between adjacent symbols introduces time-dependence among received symbols.	RNN is selected as basic neural network model.
		Channel decoding of convolutional code [49]	Convolutional channel coding inherently introduces temporal correlation in the encoded sequence.	
		Channel state information prediction [50], [51]	The wireless channel exhibits significant temporal correlation.	
Knowledge-driven GNN selection	Resource management	Power allocation problems addressed by GNN [52]–[62]	Graph-structured network topology has spatial dependency.	GNN is selected as basic neural network model.
		Link scheduling problems in ad-hoc networks [63], [64]		
		Node and link placement in network slicing problems [52], [65]–[67]		
	Signal processing	MU-MISO precoding [68], [69]; MIMO signal detection [70]–[73]	Network topology has graph-structured spatial dependency.	
Knowledge-driven CNN selection	Signal processing	CSI feedback [74], [75]; channel estimation [76]–[78]; hybrid MIMO precoding [79]–[82]	The wireless channel exhibits obvious spectral and spatial correlation.	CNN is selected as basic neural network model.

reason the probability of the real state from historical global observations by capturing the underlying knowledge about temporal correlation. Considering the dynamic load in edge networks, a deep-Q network-based distributed task offloading strategy is put forward in [41] to reduce the long-term expected cost estimated via LSTM to exploit the temporal correlation. Furthermore, LSTM has also been adopted in network slicing [42], uncrewed aerial vehicle (UAV) trajectory optimization [43] and other long-term resource management problems to capture the temporal property.

4) *Related Literature Review on Wireless Signal Processing*: In the physical layer of wireless communications, some key tasks, such as signal detection with inter-symbol interference (ISI), channel decoding of convolutional code and channel state information (CSI) prediction, demonstrate distinct time dependence. Such characteristics can be well exploited by sequence-structured neural network models, specifically RNNs and LSTM networks, to enhance performance. In light of this, RNN-based wireless signal processing works have been investigated.

For signal detection, the multi-path effect of wireless channels leads to the ISI between adjacent symbols, which introduces time dependence among received symbols. Hence, Farsad and Goldsmith [44] elected LSTM, excelling in dealing with time sequence, as signal detection architecture to counteract severe ISI. Specifically, they deployed a sliding bidirectional LSTM-based intelligent signal detector, which can not only consider the future symbol observations during the current symbol detection, but also handle the symbol of arbitrary lengths. Experiments revealed that the proposed detector, informed by the time dependence of the received symbols, outperforms the Viterbi detector and neural network detectors proposed previously. Owing to the outstanding performance, other RNN-based signal detectors are also designed in [45], [46], [47], [48] to conquer the ISI.

For channel encoding and decoding, convolutional coding inherently introduces temporal correlation in the encoded

sequence, leveraging the past and present input bits to generate each encoded output bit. This sequence's time-related characteristics can be exploited in the channel decoder for error detection and correction. To better capture such temporal correlation and enhance the reliability of wireless communications, the RNN architecture is adopted in the intelligent channel decoder [49]. It has been demonstrated that carefully crafted and trained RNNs can effectively decode convolutional codes and turbo codes transmitted over additive white Gaussian noise channels.

Besides, the wireless channel exhibits significant temporal correlation, mainly influenced by user mobility, which can facilitate CSI prediction by leveraging historical data to forecast future channel states accurately. Due to the ability to capture long-term dependencies in time-series data, researchers have employed LSTM networks for more accurate and reliable predictions of dynamically changing wireless channel conditions. Specifically, an inventive online CSI prediction scheme is proposed in [50], which adopts the LSTM network to process historical data for channel prediction. Simulation results demonstrated that it not only speeds up the generation of CSI predictions but also ensures their remarkable accuracy. Similarly, Wang et al. [51] improved the traditional CSI feedback network by incorporating LSTM into its architecture, named CsiNet-LSTM. By capturing the temporal correlation via LSTM, CsiNet-LSTM not only heightens the quality of CSI recovery but also ensures a more optimal balance between compression ratio and complexity.

5) *Design Guideline*: The key procedures to select RNN as the neural network model are summarized as follows. i) Verify that the target task involves sequential data and has temporal dependency. ii) Select the suitable RNN variant, typically LSTM, and proceed with training.

B. Knowledge-Driven GNN Selection

1) *Concept*: Knowledge-driven GNN selection refers to employing domain knowledge regarding graph-structured

spatial network topology to select GNNs as the right model. In wireless communication networks, the network topology consisting of multiple communication links naturally forms a graph in the space domain, where each node is only interdependent among its connected adjacent nodes. Due to user mobility, the graph structure-based network topology, including the number of nodes and the connecting relations among nodes, is always dynamic. By incorporating such knowledge concerning dynamic graph-structured features of network topology into the neural network model, GNN is capable of effectively handling a majority of wireless tasks with better scalability and lower training complexity [13], [83], [84]. Furthermore, another important prior knowledge broadly existing in wireless tasks, known as the permutation equivalence (PE) property, can also be exploited by GNN. This property implies that while the ordering of the outputs for each node changes following the input order, the actual values of the corresponding outputs remain unchanged [85]. Taking into account both the graph-structured spatial geometry of network topology and the permutation equivalence property of wireless tasks, GNN exhibits enhanced scalability and can effectively manage dynamic multiuser wireless tasks.

2) *Typical Example:* We take the GNN-based power allocation as an example. Consider a device-to-device communication scenario with multiple transceiver pairs, as plotted in Fig. 6(b). By treating each transceiver pair as a node and the interference link as an edge, the network topology can be modeled as a graph. Leveraging this graph-structured network topology knowledge, GNN is selected as the right neural network model for the power allocation problem to maximize the system sum rate [53]. With the ability to aggregate information from neighboring nodes, GNN scales effectively with network size, capturing both local and global dependencies, which is ideal for complex, dynamic environments. Consequently, it offers robust, adaptive power allocation with fast online inference, as verified by experimental results in [53].

3) *Related Literature Review on Wireless Resource Management:* In wireless resource management, many multiuser tasks naturally form a spatial graph-structured network topology. By embedding this structural feature into neural network models, GNNs can effectively capture the complex interactions between nodes in the network. Consequently, GNNs have been widely applied to a range of tasks, including power allocation, link scheduling, and network slicing.

For the power allocation problem, a number of works have tried to adopt various types of GNN to lower the complexity and enhance the scalability in large-scale networks. With the same graph model as the described example, in [53], Y. Shen et al. showed that large-scale resource allocation problems including the power allocation and beamforming design problem, which satisfy PE properties, can be effectively handled by message passing GNN (MPGNN) with better scalability, fewer training samples and high computational efficiency. Such benefits are further proved from

the theoretical perspective. In particular, as compared with MLP, MPGNN converges $O(n \log n)$ times faster, has $O(n)$ times less error [54], and requires $O(n^2)$ times less training samples [55], where n is the number of nodes. By showing the equivalence between MPGNN and distributed algorithms, GNN is also proved to achieve near-optimal network performance [53], [55]. With a similar GNN-based framework, the joint channel and power allocation problem in D2D networks is investigated in [56]. Unlike the homogeneous K -user interference channel scenario or D2D networks, the power allocation problem in multi-cell multi-user networks satisfies both network-level and cell-level PE properties, and the formulated graph consisting of different types of links is heterogeneous. To concurrently incorporate this prior knowledge into the neural network structure, a heterogeneous graph neural network with a parameter sharing scheme, abstracted as passing GNN, is proposed in [57], [58] to learn the optimal power policy with lower sample complexity. For the joint user association and power allocation problem in heterogeneous ultra-dense networks, the local validity and correlation attenuation of network topology is embedded into the neural network architecture and then a heterogeneous bipartite graph neural network is constructed to enjoy the scalable character in large-scale user scenarios [59]. As users in fully decentralized ad-hoc networks have different working clocks, an asynchronous aggregation GNN is proposed in [60] to learn the optimal power allocation. Furthermore, a random edge graph neural network is also proposed to investigate the fast power allocation in D2D networks [61], [62].

In addition, GNN has been utilized to solve the link scheduling problem in wireless ad-hoc networks. By modeling the interference relationship between wireless links in ad-hoc networks as a conflict graph similar to [86], a distributed link scheduler with GNN-based topology-aware node embedding is proposed in [63] to solve the maximum weighted independent set problem. Owing to leveraging the topological information, the proposed link scheduler has better network performance, good generalizability and lower complexity in networks with tens of wireless links. To tackle the multi-hop network flow problem in wireless ad-hoc networks involving the routing selection and the non-interfering link scheduling, a dynamic topology-aware DL framework is developed in [64], where the structure-level network topology information is incorporated into node and edge embedding vectors via GNN. With such a topology-aware representation, the proposed framework is robust over diversified network typologies and scenario deployments.

Due to the excellent representation of graph-structured network topology, GNN is also applied in network slicing that maps the virtual network function forwarding graph (VNF-FG) to the substrate networks with various typologies. For the virtual network embedding, a GNN-assisted reinforcement learning framework is proposed in [65] to efficiently place the nodes and links of VNF-FG on nodes and links of practical networks. To make the proposed framework scalable, both the per-VNF embedding and the global substrate network embedding are conducted via GNN in the

state representation. Considering the practical restrictions in wireless networks, a virtual network embedding algorithm and a joint network slicing and routing algorithm based on DRL and GNN are respectively developed in [66] and [67], where GNN is to extract the dynamic network topology and resource attributes. With the given VNF-FG placement, a GNN-empowered resource allocation algorithm for each VNF is investigated [52]. In the proposed algorithm, GNN is to extract the intertwined relationships among slices so that the end-to-end delay of multiple network slices can be reduced over various network topologies and parameter settings.

4) *Related Literature Review on Wireless Signal Processing:* In wireless signal processing, the interactions among multiple users or transceiver antennas inherently form a graph structure. By capturing these relationships and interdependencies, GNNs can dynamically adapt to changes in the network structure, offering robust performance even as the network evolves. Therefore, GNNs have been adopted in various wireless signal processing tasks, such as MIMO precoding and signal detection.

For precoding tasks, the multi-user (MU) multi-input single-output (MISO) communication setup is depicted as a graph, where each base station (BS) antenna and each user are represented as vertices, and the channels between them act as edges. Based on this graph, a GNN-informed full-digital precoding method is proposed in [68] to maximize the sum rate. Compared with CNN, the proposed GNN is more suited to the precoding task, achieving superior sum rates and lower training complexity with the same amount of training data. Similarly, a GNN-based intelligent beamforming strategy aiming at sum rate maximization is also investigated in an intelligent reflecting surface (IRS)-assisted MU-MISO scenario [69], which directly maps the received pilots and user locations to the beamforming vectors to reduce the number of required pilots.

For MIMO signal detection, the detection process of iterative message passing (MP) algorithms can be regarded as information interaction based on a graph, where each antenna at the transceiver is a vertex and each link among them is an edge. Inspired by this knowledge, GNNs, capable of embedding the graph-structured topology into neural networks and accelerating online processing, have become attractive neural network models for signal detection. In [70], a novel GNN-based MIMO detector combining both GNN and belief propagation algorithm is proposed for massive MIMO systems, which has a lower computation cost. In [71], a GNN-aided multiuser MIMO (MU-MIMO) detector is developed to achieve the near maximum likelihood performance across various configurations. Besides, GNN-based detectors are also investigated for MIMO-turbo receivers [72] and high-speed systems [73].

5) *Design Guideline:* The key procedures for selecting GNN as the neural network model are outlined as follows. i) Ensure that the target task involves graph-structured data, such as wireless network topology. ii) Select the relevant GNN model and initiate the training process.

C. Other Knowledge-Driven Neural Network Model Selection

In addition to temporal correlations and graph-structured network topology, other features of wireless networks can guide the selection of appropriate neural network models, such as CNNs, encoder-decoder architectures, and attention mechanisms, for specific tasks. A prime example is the use of CNNs for wireless signal processing, driven by the domain knowledge about spectral and spatial correlations of wireless channels in Euclidean space. These correlations, resulting from multi-path propagation and the presence of multiple antennas at the transceiver, make CNNs particularly well-suited due to their ability to capture local dependencies and patterns in multi-dimensional data. Leveraging this prior knowledge, numerous studies have utilized CNNs to improve the performance of wireless signal processing tasks, including channel estimation and precoding.

In channel-related applications, Wen et al. [74] developed CsiNet, a method that uses CNNs to exploit knowledge regarding spatial-frequency channel correlation in massive MIMO-OFDM systems, for efficient CSI feedback. Simulation results demonstrate that the proposed CsiNet is capable of reconstructing CSI with notably enhanced quality, particularly in areas of low compression. Similarly, a spatial-frequency CNN is proposed in [76] for the channel estimation in millimeter-wave massive MIMO-OFDM systems, informed by knowledge concerning natural spatial and frequency channel correlations. As compared with the non-ideal minimum mean-square error estimator, the proposed estimator offers superior performance and reduced complexity. Inspired by the pioneering works, a series of subsequent studies have also adopted CNN for channel feedback [75] and channel estimation [77], [78].

For MIMO precoding tasks, prior knowledge of channel spatial correlation also guides the selection of CNNs. In [79], [80], a CNN framework for the joint precoder and combiner is proposed, which can effectively handle incomplete channel matrices, leading to a robust and efficient hybrid precoding solution. By leveraging knowledge of inter-user interference correlation, Jiang et al. [81] utilize CNN attention layers for the precoder design in mmWave MIMO systems. Their proposed low-complexity, attention-based hybrid precoding outperforms existing DL-based methods in achieving a higher sum rate. Similarly, a novel CNN-based hybrid precoding approach in mmWave massive MIMO systems is investigated in [82]. This research introduces a new combiner neural network architecture that can predict RF combining vectors directly from the received CSI, leading to significant precoding performance improvement with hardware limitations and imperfect CSI.

D. Summary and Discussion

Knowledge-driven neural network model selection is well-suited for tasks with strong structural priors, such as temporal dynamics in traffic prediction or spatial correlations in non-Euclidean spaces, as commonly found in graph-structured

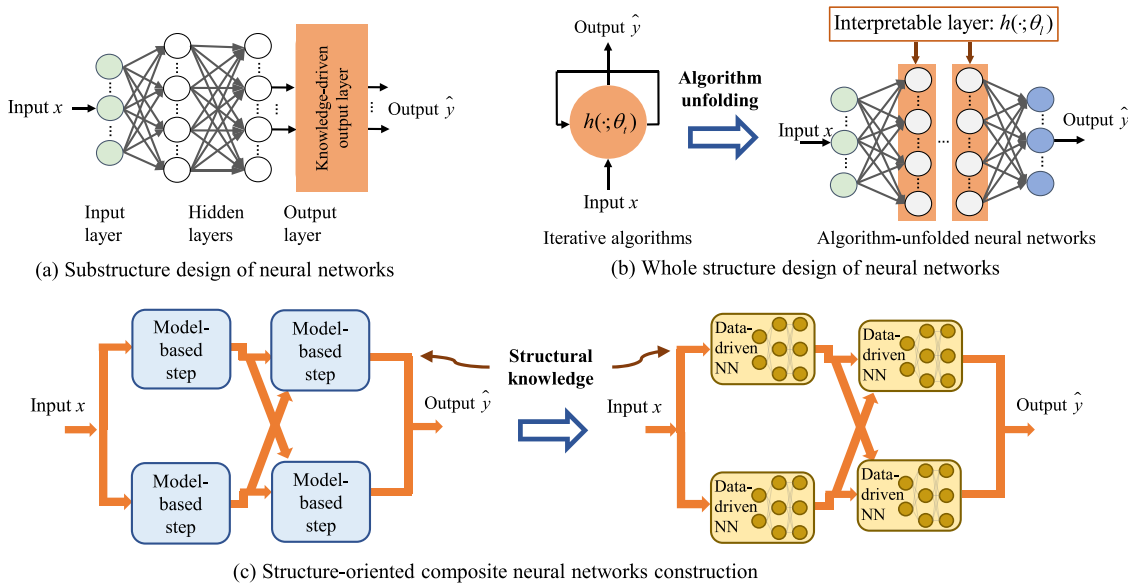

Fig. 7. The neural network model customization. The orange boxes and lines denote the integrated domain knowledge. In the substructure design of neural networks, knowledge is embedded in the output layer. In the whole structure design of neural networks, iterative algorithms are unfolded as interpretable layer-wise neural networks. In structure-oriented composite neural networks, structural knowledge inspired by model-based methods are maintained to connect neural network blocks.

wireless topologies. It implicitly integrates domain knowledge by selecting neural network models (e.g., RNNs, GNNs) whose structural properties naturally align with task-specific characteristics. This approach enhances performance and generalization, particularly in scenarios with limited training data.

V. KNOWLEDGE-DRIVEN NEURAL NETWORK MODEL CUSTOMIZATION

Compared with NLP or image recognition in the field of computer science, wireless optimization problems present greater complexity due to intricate constraints, a scarcity of labeled data, and stringent reliability demands. To tackle these challenges, communication-specific domain knowledge can be utilized to tailor original neural network models to appropriate ones, improving interpretability and adaptivity. As a consequence, the number of required training data samples is reduced and the computation burden in the offline training is relieved. According to the literature review in the field of wireless communications, as illustrated in Fig. 7, neural network model customization can be divided into three categories, i.e., the substructure design of neural networks, the whole structure design of neural networks and structure-oriented composite neural network construction. Following this categorization, the subsequent subsections introduce the concept of each approach, accompanied by a specific example. Furthermore, the relevant literature on knowledge-driven wireless resource management and signal processing will be reviewed, highlighting the involved knowledge and knowledge integration approaches, as outlined in Table IV.

A. The Substructure Design of Neural Networks

1) *Concept*: The substructure design of neural networks, depicted in Fig. 7(a), incorporates domain knowledge into the

local structure of neural networks, such as the output layer or the activation function, to make the outputs adhere to some properties. In wireless communications, network optimization tasks usually come with resource constraints that existing basic neural network models can not effectively manage. This challenge can be mitigated by integrating communication-specific domain knowledge into the output layer of neural networks, which guarantees that the outputs generated by neural networks fall within the feasible region of the target problem. The integrated knowledge stems from methodologies for modeling wireless networks and the understanding of constraints in tasks, often represented by mathematical formulas.

2) *Typical Example*: An illustrative example of this approach is adopting the special projection function in the output layer to handle a constrained MISO beamforming problem. Specifically, consider a downlink multicast MISO scenario, where a BS equipped with N antennas simultaneously serves M single-antenna users. Let \mathbf{w} and \mathbf{h}_m denote the beamforming vector and channel from BS to user m . The power minimization problem with each user's signal-to-ratio (SNR) constraint is formulated as

$$\max_{\mathbf{w} \in \mathbb{C}^N} \|\mathbf{w}\|_2^2 \quad (1a)$$

$$\text{s.t. } \frac{|\mathbf{h}_m^H \mathbf{w}|^2}{\sigma_m^2} \geq \gamma_m, \forall m \in \{1, \dots, M\}, \quad (1b)$$

where σ_m^2 and γ_m respectively denote the received noise power and the SNR threshold of user m .

Due to the nonconvex constraint (1b), this problem is typically addressed by the semi-definite relax (SDR) technique with high computational complexity. Applying DL can significantly reduce the online processing complexity, but a challenge lies in ensuring that beamforming meets SNR constraints. Through theoretical analysis via the complementary slackness

TABLE IV
KNOWLEDGE-DRIVEN NEURAL NETWORK MODEL CUSTOMIZATION

Specific integration approach	Areas in wireless networks	Applications	Specific integrated knowledge		Specific knowledge integration approach
Substructure design of neural networks	Resource management	Power allocation problems with simple constraints [88]–[91]	Comprehensive understanding of constraints in wireless resource management problem		The constraint is converted as the output layer of neural networks to project solutions to feasible domain.
		Power allocation for over-the air FL [92]	The structure of the analytical expression of the transmission power		The power structure is designed as the output layer.
	Signal processing	Downlink SINR balancing problem [93], [94]	There exists a theoretically demonstrated uplink-downlink duality between the downlink SINR balancing problem and the transmission power minimization problem.		The optimal downlink beamforming structure is a neural network mapping the uplink power mapping with an analytical output layer recovering the downlink beamforming.
		Signal processing problems with simple constraints [95], [96]	Comprehensive understanding of simple constraints in signal processing problems		Simple constraints are converted as output layer of neural networks.
Whole structure design of neural networks	Resource management	Power allocation problems [97], [98] [18], [99], [100]	Model-based iterative algorithms for resource management problems		Iterative algorithms is unfolded as customized neural networks via deep unfolding approaches.
		Power allocation in energy harvesting communication networks [101], [102]	The monotonicity of the optimal power derived from theoretical algorithms		The monotonicity is involved to construct customized neural networks.
	Signal processing	Beamforming design [103]–[112] [113]–[116]	WMMSE algorithm, gradient descent algorithm for beamforming, iterative penalty dual decomposition algorithm		Model-based iterative algorithms is unfolded as customized neural networks via algorithm unfolding approaches.
		Signal detection [117]–[133]; channel estimation [134]–[146]; joint channel estimation and user activity detection [147]–[152]	Optimization-based iterative algorithms		
			Message-passing iterative algorithms		
Structure-oriented composite neural networks	Resource management	Meta-learning based alternating iterative framework [153] and its applications [154]–[157]	The structure of model-based algorithms	The structure of alternating minimization algorithms	The structure is maintained in composite neural networks.
		Power allocation in cellular systems [158]		The iterative structure with proved convergence	Composite neural network with iterative structure is constructed.
	Signal processing	Block-wise OFDM receiver [159], [160]	The block-wise design principle of the transceiver		OFDM receiver is with two neural network blocks respectively for channel estimation and signal detection.
		MU-MIMO signal detection [161]; linear channel decoding [162]	The structure of model-based algorithms		The structure is maintained in composite neural networks.

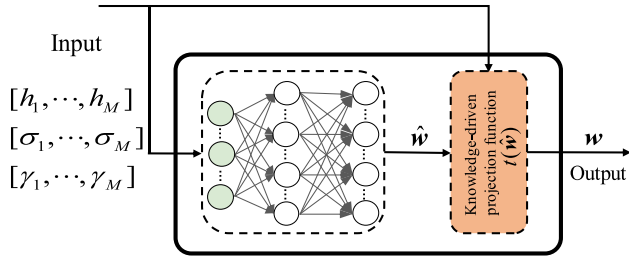

Fig. 8. A knowledge-driven projection function for multicast beamforming.

condition, it is evident that optimal beamforming lies on the boundary of the feasible region. Inspired by this knowledge, the beamforming vector is represented as $\mathbf{w} = t\hat{\mathbf{w}}$, where the scaling variable t is a function of $\hat{\mathbf{w}}$ to ensure all constraints in (1b) are met, with at least one active. As illustrated in Fig. 8, a knowledge-driven substructure design of neural networks is proposed in [87], incorporating a customized projection function $t(\hat{\mathbf{w}})$ defined in (2) as the output layer to deal with the infeasible and nonoptimal outputs. Simulation results show that the proposed knowledge-driven DL extremely outperforms the SDR technique in both the system performance and the online processing time.

$$t(\hat{\mathbf{w}}) = \begin{cases} 1 & \frac{|\mathbf{h}_m^H \hat{\mathbf{w}}|^2}{\sigma_m^2} \geq \gamma_m, \forall m, \\ \max_{m \in \{1, \dots, M\}} \sqrt{\frac{\sigma_m^2 \gamma_m}{|\mathbf{h}_m^H \hat{\mathbf{w}}|^2}} & \text{Otherwise.} \end{cases} \quad (2)$$

3) *Related Literature Review on Wireless Resource Management:* In resource management, ensuring that networks' decisions align with the systems' constraints and requirements is very critical. To achieve this, the substructure design of neural networks has been applied in wireless power allocation tasks, where domain knowledge regarding a deep understanding of resource constraints is integrated into the output layer of the neural networks.

To address the downlink multicell power allocation problem for sum rate maximization with per-user rate constraints and per-BS power constraints, a novel DNN framework is proposed [88], [89]. Within this framework, a knowledge-driven output block is added following the conventional DNN to project the results onto the feasible domain, which is devised based on a geometrical interpretation of the per-user rate constraints. Benefiting from the embedded knowledge block, the proposed DNN framework can effectively deal with the model mismatch problem between training and testing datasets. In [90], a new activation function at the output layer is designed based on the softmax to make the learned power maximize the sum rate while satisfying the sum power constraint. For the power allocation problem in energy-efficient predictive video streaming transmission, a safety layer, which is derived in closed form by exploiting the knowledge about the transitions of the user's buffer state, is added as an additional output layer of the original neural network to satisfy the QoS constraint that the video segment is downloaded before being played [91]. In [92], to minimize the time-average learning efficiency of the aggregated global model for

over-the-air federated learning, a knowledge-driven learning algorithm is proposed for the power allocation and the receive normalizing factor selection, where an additional output layer inheriting the structure of the analytical expression of the transmission power is added behind a DNN.

4) *Related Literature Review on Wireless Signal Processing*: In wireless signal processing, domain knowledge embedded in the substructure of neural networks often originates from the comprehensive understanding of tasks, such as the uplink-downlink duality, the structure of the optimal solution to a problem and the smart transformation of basic signal processing constraints. Such knowledge is usually incorporated as the differentiable output layer of neural networks, which can reduce the learnable parameters or generate solutions strictly within the feasible region. Owing to these benefits, customized substructure design of neural networks has been initially applied in MIMO beamforming problems.

In [93], a knowledge-driven DL framework for MISO downlink beamforming is proposed, which includes a neural network for feature extraction and a knowledge-embedded output layer for beamforming recovery. Specifically, for the downlink signal to interference plus noise ratio (SINR) balancing problem and transmission power minimization problem, there exists a theoretically demonstrated uplink-downlink duality, which indicates that the downlink beamforming can be derived based on the uplink transmission power in an analytical expression. Hence, the corresponding beamforming learning problem can be converted into an uplink power mapping problem with a beamforming recovery layer. Then, informed by the structure of the optimal beamforming vector derived from power allocation vectors, the same framework can also be applied to the downlink sum-rate maximization problem [93], [94]. In this application, the neural network is only required to predict two low-dimensional power allocation vectors, which are subsequently used in the knowledge-driven output layer to analytically recover the high-dimensional beamforming vectors. Compared with existing algorithms, this proposed framework achieves a good balance between performance and complexity. Another notable work is the integration of discrete constraints within the output layers of neural networks for simultaneous antenna selection and hybrid beamforming, as explored in [95]. Particularly, a probabilistic subsampling technique and a tailored quantization function are implemented in the output layers of the antenna selection and hybrid beamforming networks, respectively. These adaptations maintain differentiability while adhering to the antenna selection and analog beamformer constraints, enhancing both the performance and computational efficiency. In [96], to satisfy the module-1 constraint for the analog beamformer, a novel Lambda layer related to the Euler function is added at the output layer.

5) *Design Guideline*: The primary steps to design a knowledge-driven neural network substructure are given as follows. i) Conduct a thorough analysis of the target problem to uncover key insights (i.e., domain knowledge) that can help reformulate constraints or reveal the underlying structure of the solution. ii) Utilize the identified insights to customize specific

components of the neural network, such as the activation function or output layer, ensuring they align with the problem's requirements. iii) Verify that the designed substructure is differentiable and train the entire neural network in an end-to-end manner.

B. The Whole Structure Design of Neural Networks

1) *Concept*: The whole structure design of neural networks employs communication-specific domain knowledge to completely devise novel neural networks, tailored to particular tasks. The most representative approach of this category is the algorithm unfolding creatively proposed by Greger and LeCun [163], which embeds knowledge regarding proven iterative algorithms into the whole structure of neural networks. Essentially, as shown in Fig. 7(b), algorithm unfolding takes a classic iterative algorithm, derived from theoretical solutions to network optimization, and unfolds it into a sequence of mathematical operations over a set number of iterations. By treating each iteration of the algorithm as a layer of a neural network, a customized neural network model can be constructed, which mirrors the structure and logic of the original algorithm. This approach also enables the fixed parameters in the algorithm to be flexibly learnable parameters in the neural network, thus infusing the neural network model with adaptability while preserving the interpretability of the iterative algorithm. Owing to these benefits, algorithm unfolding has been widely adopted across a range of wireless network tasks that have a wealth of theoretical iterative algorithms.

2) *Typical Example*: We take intelligent signal detection as an example, where a tailored neural network, DetNet, is unfolded by the projected gradient descent algorithm [117]. For a communication link between N_t -antenna transmitter and N_r -antenna receiver, the observed signal at the receiver is expressed as $\mathbf{y} = \mathbf{H}\mathbf{x} + \mathbf{n}$, where $\mathbf{x} \in \mathcal{X}^{N_t}$ is the vector of transmitted symbols with \mathcal{X} denoting the finite set of constellation points, $\mathbf{H} \in \mathbb{C}^{N_r \times N_t}$ is channel matrix and $\mathbf{n} \in \mathbb{C}^{N_r} \sim \mathcal{CN}(\mathbf{0}, \sigma^2 \mathbf{I}_{N_r})$ is the noise vector with σ^2 being the noise power. To detect the signal at the receiver, the maximum likelihood (ML) decoder is formulated as

$$\hat{\mathbf{x}} = \underset{\mathbf{x} \in \mathcal{X}^{N_t}}{\operatorname{argmin}} \|\mathbf{y} - \mathbf{H}\mathbf{x}\|_2^2. \quad (3)$$

Due to the NP-hard nature of problem (3) caused by the finite-alphabet constraint $\mathbf{x} \in \mathcal{X}^{N_t}$, a classical iterative projected gradient descent algorithm (outlined in Algorithm 1) is proposed to address it with manageable computational complexity, where $\mathcal{P}_{\mathcal{X}}(\cdot)$ is the nonlinear projection operator into \mathcal{X} .

To further reduce the online processing time, knowledge regarding the projected gradient descent (PGD) algorithm is integrated to design a customized neural network via the algorithm unfolding approach. Specifically, in Algorithm 1, each iteration is a linear combination of the $\hat{\mathbf{x}}^t$, $\mathbf{H}^H \mathbf{y}$ and $\mathbf{H}^H \mathbf{H} \hat{\mathbf{x}}^t$ followed by a non-linear projection. By involving this knowledge in each layer of DNN and treating the step size

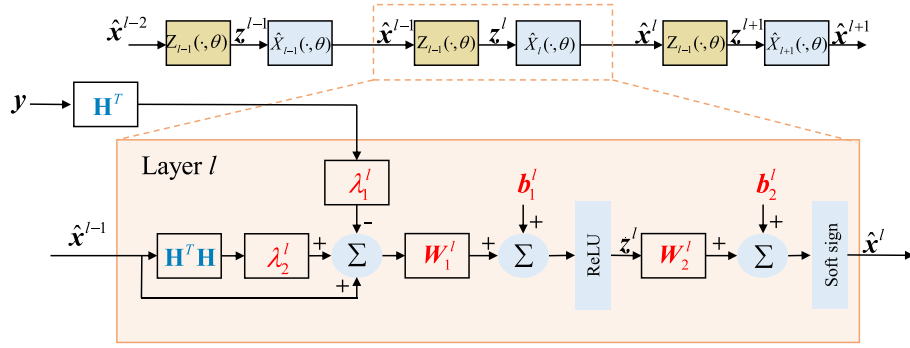

Fig. 9. A knowledge-driven intelligent signal detector via algorithm unfolding.

Algorithm 1 Project Gradient Descent Algorithm for Signal Detection

- 1: Initialize step size λ ;
 - 2: **for** $t = 0, 1, \dots$ **do**
 - 3: Update $\mathbf{z}^t = \hat{\mathbf{x}}^t + 2\lambda^t \mathbf{H}^H \mathbf{H} \hat{\mathbf{x}}^t - 2\lambda^t \mathbf{H}^H \mathbf{y}$;
 - 4: Update $\hat{\mathbf{x}}^{t+1} = \mathcal{P}_{\mathcal{X}}(\mathbf{z}^t)$;
 - 5: **end for**
 - 6: **return** $\hat{\mathbf{x}} = \hat{\mathbf{x}}^{t+1}$.
-

λ as a learned parameter, the structure of knowledge-driven DetNet, shown in Fig. 9, is formulated as

$$\mathbf{z}^l = \text{ReLu}\left(\mathbf{W}_1^l \left((\mathbf{I} + \lambda_2^l \mathbf{H}^H \mathbf{H}) \hat{\mathbf{x}}^l - \lambda_1^l \mathbf{H}^H \mathbf{y} \right) + \mathbf{b}_1^l \right), \quad (4)$$

$$\hat{\mathbf{x}}^{l+1} = \text{Soft Sign}\left(\mathbf{W}_2^l \mathbf{z}^l + \mathbf{b}_2^l\right), \quad (5)$$

where $\theta = \{\mathbf{W}_1^l, \mathbf{W}_2^l, \mathbf{b}_1^l, \mathbf{b}_2^l, \lambda_1^l, \lambda_2^l\}_{l=1}^L$ is the trainable parameters and L is the total number of layers. The experiments reveal that, when provided with sufficient training examples, DetNet outperforms conventional MIMO detection algorithms based on approximate message passing and semi-definite relaxation.

3) *Related Literature Review on Wireless Resource Management*: In wireless resource management, domain knowledge, including theoretical algorithms and their properties, is often incorporated to fully tailor the neural network structure. This approach, with the advantages of improving interpretability and reducing computational complexity, has been first applied to power allocation problems through a comprehensive neural network structure design.

As the most typical knowledge-driven neural network structure design approach, algorithm unfolding, constructing layers of neural networks by borrowing iterations of iterative algorithms, has been initially applied to wireless power allocation problems. For the sum rate maximization problem in wireless ad-hoc networks, the classical power allocation algorithm is the iterative WMMSE algorithm. To simultaneously embed the graph-structured network topology into neural networks for scalability enhancement, WMMSE-unfolded GNNs have been extensively investigated. In [97], [98], a WMMSE-inspired GNN in ad-hoc networks is proposed, which learns key parameters of the WMMSE algorithm with GNN without unfolding iterations in the WMMSE algorithm as layers in GNN. To

align the GNN architecture with the algorithm itself [164], a novel GNN architecture based on the unfolding of the WMMSE algorithm is constructed in [18], which consists of three neural network modules to mimic the three variables' update in the WMMSE algorithm. For each variable update, the adjacent information collection process is implemented via the aggregation function of GNNs. As demonstrated in the simulation, this architecture enhances the representation of the GNN and reduces the sample complexity. Owing to these benefits, other model-based algorithms like successive convex approximation (SCA) for the sum energy efficiency maximization [99] and decentralized gradient descent [100] are also unfolded as GNNs.

Furthermore, properties derived from theoretical algorithms can also be incorporated into the structure of neural networks. To avoid the large computation load on devices brought by conventional deep neural networks, in [101], a lightweight reinforcement learning architecture guided by structural properties derived from the optimal power allocation strategy is established in energy harvesting communication networks. Specifically, the monotonicity of the optimal policy as well as the upper and lower bound for the output of the policy network is theoretically proved. This knowledge is embedded by constructing the neural network with the piecewise linear calibration and interpolation method [102], which are capable of shaping the function approximator with various desirable structural properties. As expected, the proposed lightweight DRL outperforms existing methods.

4) *Related Literature Review on Wireless Signal Processing*: In wireless signal processing, the involved domain knowledge in whole neural network structure design usually stems from model-based theoretical algorithms. The knowledge embedding process is mainly achieved by the innovative algorithm unfolding approach. By preserving the fundamental structure of theoretical iterative algorithms, algorithm unfolding offers both interpretability and rapid online inference. Therefore, it has been widely adopted in wireless signal processing tasks with classical model-based iterative algorithms, including beamforming design, signal detection, channel estimation, and joint channel estimation and user activity detection.

(a) In beamforming design, the classical WMMSE algorithm proposed by Shi et al. [103], aiming to maximize the weighted system sum rate subject to the transmission power constraint,

has been embedded into different neural network models. To reduce online processing time and keep interpretability, a general framework of iterative WMMSE-unfolded customized DNN is developed in matrix form for the multi-user MIMO scenario [104], [105], [116]. Within this framework, the non-linear matrix inversion operation in the original WMMSE algorithm is also approximated by its first-order Taylor expansion and corresponding learnable matrices to avoid high computational complexity. In [106], [107], another matrix-inverse-free WMMSE informed DNN is proposed for the multi-user MISO scenario, where the update of the beamforming vector with matrix inverse operation is replaced by PGD and unfolded as a PGD-inspired neural network. Furthermore, a customized GNN with the unfolding of WMMSE is devised in [108] for the multi-cell multi-user MIMO scenario. As both the knowledge of the iterative WMMSE algorithm and the graph-structured network topology are embedded, the proposed WMMSE-unfolded GNN exhibits a low number of trainable parameters.

In addition to the WMMSE algorithm, other iterative algorithms, are also embedded in the structure of neural networks to design the intelligent beamforming matrix for various performance metrics. In [109], the gradient descent algorithm for the sum rate maximization is unfolded as a layer-wise residual neural network to devise adaptive beamforming vectors. In [110], an iterative penalty dual decomposition algorithm for the hybrid beamforming design in mmWave communications is unfolded as a customized layer-wise DNN to maximize the spectrum efficiency. Then, for two timescale beamforming in IRS-assisted wireless communication systems, WMMSE-based and fractional programming-based short-term active beamforming algorithms are respectively unfolded as customized DNNs in [111], [112] and [113] to facilitate the calculation of the gradient for the long-term passive beamforming. Moreover, iterative algorithm-involved deep unfolding neural networks are investigated for the finite-alphabet precoding [114], [129] and the max-min multicast beamforming design [115].

(b) In signal detection, a series of model-based iterative detection algorithms have been developed based on the ML and the maximum a posteriori (MAP) criteria. These algorithms, originally designed under the assumption of an ideal Gaussian channel, face limitations in adapting to the more complex and realistic non-Gaussian environments. To overcome this issue and speed up online processing, novel knowledge-driven intelligent detectors are proposed via the algorithm unfolding approach, which deeply incorporates the explainable classical algorithms into the structure of neural networks. For ML-oriented MIMO signal detectors, a series of optimization-based iterative algorithms are unfolded as customized neural networks. A tailored neural network inspired by the PGD algorithm, referred to as DetNet, was proposed in [117]. By involving the iterative process of the PGD algorithm in DNN and treating step sizes as learnable parameters, DetNet outperforms conventional MIMO detection algorithms in the experiments. Similar PGD-unfolded neural networks are also proposed to detect the signal in massive overloaded MIMO channels [118], [119], imperfect MIMO

systems [120], and multilevel modulation systems [121]. In addition, the alternating direction method of multipliers (ADMM)-based iterative algorithm is also unfolded as a structured DNN, named ADMM-Net, to solve the MIMO detection problem [122], [123]. Motivated by the theory of iterative soft thresholding algorithms, MMNets, an unfolded adaptive neural network for MIMO signal detection, is proposed for both i.i.d Gaussian channels and arbitrary channels [124].

For MAP-oriented signal detectors, the interactive relationship between antennas in the transceiver is modeled as a probabilistic graph, where the log-likelihood ratios messages are iteratively passed [125]. The resulting algorithms, called MP-based iterative algorithms, have also been unfolded as neural networks. By unfolding the belief propagation algorithm, a general knowledge-inspired DNN architecture for MIMO detection is introduced [126], [127], where correction factors, consisting of damping, re-scaling, and offset factors, are learned parameters. Then, the expectation propagation algorithm, which approximates posterior beliefs with exponential family distributions, is integrated into DNN as EPNet in the Turbo-MIMO receiver to detect the MIMO signal [128]. To further reduce the complexity, the structure of the signal detector in [129], [130] is obtained by unfolding the orthogonal approximate MP (OAMP) detector, referred to as OAMPNet. To avoid the operation of matrix inversion in the detector, the conjugate gradient descent [131] is adopted in OAMPNet to construct a novel signal detector [132], [133]. All these algorithm-unfolded intelligent signal detectors show fast online inference time and better adaptation for dynamic channel environments.

(c) In channel estimation, the compressive sensing theory is applied by exploiting the channel sparsity of MIMO systems in the space domain. Based on the known orthonormal basis, the MIMO channel estimation is to recover a sparse channel vector from received pilots, which is a sparse linear inverse problem [134] and can be solved by MP-based iterative algorithms and optimization-based iterative algorithms. To reduce online computational complexity and achieve real-time channel estimation, several works have been carried out to unfold these algorithms as tailored layer-wise neural networks. For the approximate MP (AMP) algorithm containing a linear estimator and a nonlinear shrinkage function, learned denoising-based AMP neural networks are proposed in [135], [136], where the original nonlinear shrinkage function in AMP is unfolded as denoising CNN. To further enhance the accuracy, multiple-measurement-vector learned AMP networks are proposed, where the shrinkage function is approximated as the nonlinear activation function [137], especially the soft thresholding function [138] and the Gaussian mixture function [139]. Moreover, the expectation maximization algorithm, another kind of MP algorithm derived based on the MAP criteria [140], is also involved in the structure of neural networks for channel estimation in MIMO systems [141], [142], [143]. For optimization-based iterative algorithms, a recursive least square (LS) algorithm-unfolded neural network for channel estimation in massive MIMO systems is proposed [144], which has low computational complexity and signaling overhead. With the off-grid channel

model, a novel ADMM-informed neural network structure is constructed to improve the channel estimation accuracy in millimeter wave systems [145]. To make the number of iterations required for convergence vary with channel conditions, a creative neural network framework with adjustable depth is devised in [146], where extra halting scores are involved in each layer to adaptively control the number of network layers. With this framework, both the iterative shrinkage threshold algorithm (ISTA) and the PGD unfolded adaptive neural networks are developed for channel estimation [146].

(d) In joint channel estimation and user activity detection for Internet of Things (IoT) networks with massive devices, the grant-free random access protocol is adopted to reduce the access delay [165], where IoT devices can initiate data transmission without any coordination with the BS and then the BS jointly performs channel estimation and active user identification before signal detection. As only a small fraction of massive devices are active at a time, the joint channel estimation and user activity detection is a group-sparse channel recovery problem, which can be modeled as the group least absolute shrinkage and selection operator problem. Similar to the channel estimation problem in MIMO systems, the formulated problem can be solved by MP-based iterative algorithms [166], [167], [168] and optimization-based iterative algorithms [169], [170], [171]. For MP algorithm-unfolded neural networks, by constructing the group-sparse channel recovery problem as a factor graph [172], iterative MP-based sparse Bayesian learning is unfolded as a tailored DNN to reduce the online processing time and improve the estimation accuracy [147], [148]. Besides, AMP-unfolded deep neural networks are proposed in [149], [150], [151] to concurrently detect the user activity, the delay and estimate the channel for the asynchronous massive connectivity problem. For optimization algorithm-unfolded neural networks, by inheriting the structure of the ISTA algorithm, three ISTA-informed neural networks are proposed in [152], which exhibit better adaptability to dynamic environments.

5) *Design Guideline*: The application of the algorithm unfolding to design the whole structure of neural networks consists of the following steps. i) Identify an iterative algorithm for the target problem. ii) Determine the learnable parameters in the algorithm like the stepsize and fix the number of iterations. iii) Design each layer of the neural network by mimicking each iteration of the algorithm and train it in an end-to-end fashion. In this way, both the structure of the iterative algorithm and the powerful fitting ability of the neural network are maintained, resulting in enhanced performance and efficiency.

C. Structure-Oriented Composite Neural Networks

1) *Concept*: In structure-oriented composite neural networks, a novel neural network consisting of multiple neural network blocks is constructed, where these blocks are interconnected by the underlying structure of theoretical model-based methods, referred to as structural knowledge. This type of neural network, guided by structural knowledge, is crafted for tasks that are addressed by algorithms represented

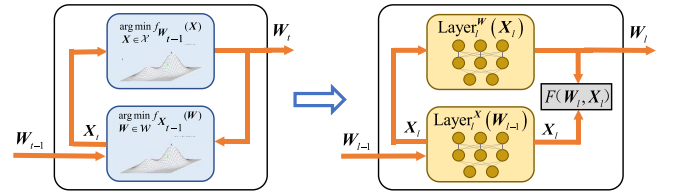

Fig. 10. An AM structure inspired composite neural network for multi-variable optimization problems.

as flow diagrams connecting multiple sub-algorithmic blocks. Following the sequential and parallel connectivity of these blocks and substituting the handcrafted sub-algorithm in each block with a distinct neural network, a structure-oriented composite neural network can be built as Fig. 7(c). Due to adhering to the flow structure of model-based algorithms, structure-oriented composite neural networks exhibit good interpretability as well as fast online inference. Furthermore, different from model-based multiblock algorithms optimizing each block with local objectives, the resulting composite neural networks are trained from a global perspective, having the potential to get rid of locally optimal solutions.

2) *Typical Example*: To reap the benefits above, a structure-oriented composite neural network is proposed in [153] to deal with nonconvex optimization in wireless networks. Consider a general problem formulated as

$$\min_{(\mathbf{W}, \mathbf{X}) \in \mathcal{W} \times \mathcal{X}} F(\mathbf{W}, \mathbf{X}) \quad (6)$$

where $F: \mathcal{W} \times \mathcal{X} \rightarrow \mathbb{R}$ is a nonconvex function. Traditionally, this problem is tackled with an alternating minimization (AM) algorithm, which iteratively optimizes each variable (e.g., \mathbf{W} and \mathbf{X}) while keeping the other fixed. Mathematically, starting by $\mathbf{W}_0 \in \mathcal{W}$, \mathbf{W} and \mathbf{X} in the t -th iteration are updated via

$$\mathbf{X}_t = \operatorname{argmin}_{\mathbf{X} \in \mathcal{X}} f_{\mathbf{W}_{t-1}}(\mathbf{X}) \quad (7)$$

$$\mathbf{W}_t = \operatorname{argmin}_{\mathbf{W} \in \mathcal{W}} f_{\mathbf{X}_{t-1}}(\mathbf{W}) \quad (8)$$

where $f_{\mathbf{W}_{t-1}}(\mathbf{X})$ and $f_{\mathbf{X}_{t-1}}(\mathbf{W})$ respectively correspond to \mathbf{W} and \mathbf{X} with the other variable fixed. Each subproblem is addressed by a model-based algorithm like the gradient descent method.

However, AM often converges to a local optimum. To improve on this, a structure-oriented composite neural network proposed in [153] adopts the AM structure (referred to as structural knowledge) but replaces handcrafted algorithms for each subproblem with dynamic neural network layers, as shown in Fig. 10. In this model, the k -th layer of the neural network is expressed as

$$\mathbf{X}_l = \operatorname{Layer}_l^{\mathbf{X}}(\mathbf{W}_{l-1}) \quad (9)$$

$$\mathbf{W}_l = \operatorname{Layer}_l^{\mathbf{W}}(\mathbf{X}_l) \quad (10)$$

where the number of layers is fixed with $l = L$. Unlike AM optimizing subproblems with local objective functions, this neural network is designed to optimize a global function across all layers, leading to enhanced performance.

3) *Related Literature Review on Wireless Resource Management*: In wireless resource management, structure-oriented composite neural networks are usually adopted to handle complicated non-convex resource allocation problems involving multiple coupled variables. Traditionally addressed with alternating iterative algorithms, these problems now can be tackled by retaining the flow of iterative algorithms while replacing manual blocks with adaptive neural networks.

When applying the structure-oriented composite neural network stated in the typical example to the power allocation problem in downlink networks, the proposed framework outperforms the WMMSE algorithm in terms of the network rate and the inference time [155]. Besides, this framework is also adopted for task offloading in vehicular networks [156]. Similarly, a joint relay deployment, channel allocation and relay assignment problem in UAV-aided D2D networks is tackled by an algorithmic structure-aware neural network [157], where the alternating iterative structure of the theoretical algorithm is maintained and each sub-problem is solved via a dynamic neural network. In addition, a creative neural network with an iterative structure is devised to learn the power allocation in cellular systems [158], where each iterative layer consists of a model function represented by the formula of data rate and an updated network represented by a neural network. As the convergence of this proposed iterative structure-oriented neural network can be theoretically proved, the required training samples are considerably reduced.

4) *Related Literature Review on Wireless Resource Management*: In wireless signal processing, structural knowledge mainly stems from the conventional block-wise transceiver design principles and the structural framework of model-based signal processing algorithms. Drawing inspiration from such knowledge, structure-oriented composite neural networks have been initially applied in block-wise transceiver design and multi-user signal detection.

The block-wise design principle of the transceiver in wireless communications refers to that baseband signal processing is implemented block by block, primarily composed of channel encoding, and precoding at the transmitter, and channel estimation, signal detection and channel decoding at the receiver. This block-wise design does indeed have theoretical foundations such as Shannon's law, which dictates that the maximum efficiency of any communication channel can be more easily approached in a block design by optimizing individual blocks to handle their part of the signal processing chain as efficiently as possible. It also enhances the flexibility and efficiency of the communication networks. Drawing inspiration from this design principle, block-wise intelligent receivers have been investigated. In [159], [160], structural-oriented composite neural networks are created for the OFDM receiver, composed of two neural network blocks respectively, for channel estimation and signal detection. Compared with the pure closed-box receiver, the proposed knowledge-driven block-wise neural network approach achieves much better bit error rate performance in all cases. In [173], a knowledge-driven neural network architecture is designed for signal detection, including a signal classifier, a channel feature extractor, a signal feature extractor and an additional link

discriminator. Due to mirroring the block structure adopted in classical communication receivers, the proposed knowledge-driven signal detector achieves superior detection accuracy with less data.

To meet millisecond-level response requirements, structural-oriented composite neural networks have been employed to tackle complex non-convex signal processing tasks, such as MU-MIMO signal detection, offering strong interpretability and fast online inference. In [161], by borrowing the structural framework of the iterative soft interference cancellation (SIC) algorithm and replacing the hand-crafted algorithmic blocks with neural networks, N. Shlezinger et al. proposed a structural knowledge-driven neural network, abstracted as deepSIC, for MU-MIMO signal detection. Simulation results demonstrate that DeepSIC can accurately detect the signal with limited training samples without the linear channel assumption. Similarly, a neural network architecture inspired by belief propagation algorithms is constructed in [162] to decode the linear channel codes, effectively lowering computational complexity.

5) *Design Guideline*: The design of structure-oriented composite neural networks consists of the following steps. i) Identify a well-defined algorithm with a structured flow that connects multiple sub-algorithms (e.g., AM structure) suitable for addressing the target problem. ii) Preserve the overall algorithm structure and substitute the handcrafted sub-algorithmic components with learnable neural network modules. iii) Train the designed composite neural network either end-to-end or by optimizing each neural network block individually.

D. Summary and Discussion

Knowledge-driven neural network model customization offers a principled way to embed domain knowledge, such as algorithmic structures, constraint formulations, and system insights, directly into neural network design. Three main customization approaches are proposed. (1) Substructure design incorporates knowledge at the component level (e.g., activation functions or output layers) without altering the overall architecture. It is particularly effective for tasks with explicit mathematical constraints or output structures, such as constrained beamforming and power control, to make the outputs adhere to feasible regions. (2) The whole structure design targets problems with established iterative solutions, like signal detection or channel estimation. This approach unfolds classical algorithms (e.g., PGD, WMMSE) into layer-wise neural architectures, preserving interpretability while allowing trainable flexibility. Thirdly, structure-oriented composite networks are suited for multi-block or joint optimization tasks, where the solution can be decomposed into interrelated modules. Inspired by block-wise strategies (e.g., alternating minimization), each module is implemented as a dedicated neural component, supporting modular training and system-level transparency. Together, these approaches enable models that are more interpretable, constraint-aware, and sample-efficient, especially in complex or resource-constrained wireless environments.

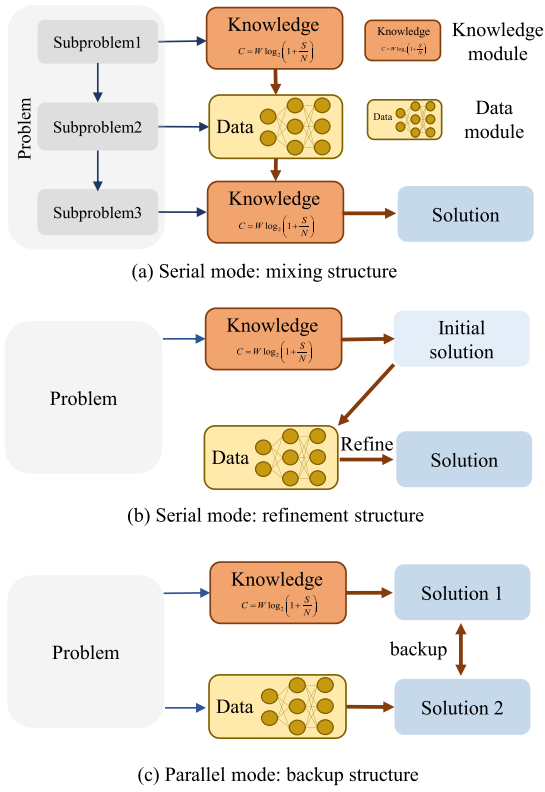

Fig. 11. The knowledge and data fusion architecture.

VI. KNOWLEDGE AND DATA FUSION ARCHITECTURE CONSTRUCTION

In knowledge and data fusion architecture, model-based theoretical methods, referred to as knowledge modules, and data-driven neural networks, referred to as data modules, are explicitly working in collaboration to solve the same problems. For wireless network optimization problems, the integrated knowledge in this category primarily stems from scientific knowledge, especially the theoretical solutions to network optimization, expressed in mathematical formulas and iterative algorithms. According to the connectivity of knowledge and data modules, as illustrated in Fig. 11, knowledge and data are fused in serial or parallel mode, where two types of modules operate successively and concurrently, respectively. Generally speaking, the serial mode is primarily used for tackling complex multi-dimensional optimization problems or improving decision accuracy, whereas the parallel mode is more suited for enhancing the robustness of simpler problems. In the following subsections, the concepts and typical examples of both modes are presented, along with a review of the relevant literature on wireless resource allocation and signal processing. An outline of the review is summarized in Table V.

A. Knowledge and Data Fusion in Serial Mode

1) *Concept*: In the serial mode, the knowledge and data modules operate in sequential order to collectively solve the target problems. Based on whether knowledge and data modules address identical sub-problems, the serial mode includes two structures: i.e., the mixing structure and the

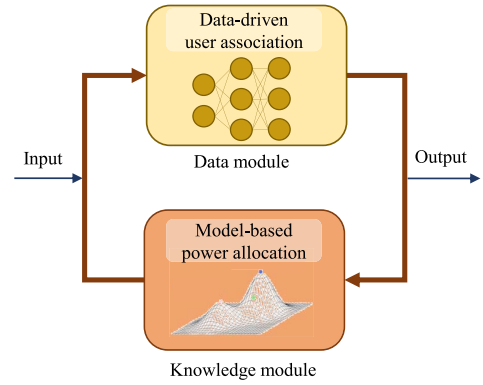

Fig. 12. A mixed serial knowledge and data fusion architecture for the joint user association and power allocation problem.

refinement structure. In mixing structures, as Fig. 11(a) shows, knowledge and data modules respectively address different sub-problems with distinct properties, capitalizing on their inherent strengths. The underlying concept involves dividing the original complex problem into several interrelated sub-problems, each addressed by either knowledge modules or data modules. Typically, sub-problems that have optimal analytical solutions or low-complexity theoretical algorithms are managed with knowledge modules, while those with high-dimensional and challenging-to-model mapping relationships are handled by data modules. Consequently, mixing structures have proven efficient in solving complicated non-convex resource management problems in wireless networks. In contrast, refinement structures, depicted in Fig. 11(b), adopt knowledge modules to initially offer approximate solutions based on generalized theoretical models. The subsequent data module then refines these solutions by leveraging real-world data. The utilization of initial solutions generated by knowledge modules significantly decreases the number of training data samples required for data modules. In wireless communication networks, refinement structures are widely employed in signal processing tasks, especially channel estimation and signal detection, where a wealth of theoretical algorithms is available to provide initial solutions.

2) *Typical Examples*: For the mixed structure in serial mode, the joint user association and power allocation problem [174] serves as an example. In a scenario where several base stations serve multiple users, maximizing the worst-case user rate involves nonlinear mixed integer programming. Solving it with the model-based AM algorithm, which alternates between user association and power allocation, is time-intensive. Given the combinatorial complexity of user association and the achievability of deriving optimal power allocation through linear programming, a hybrid framework fusing DNN and domain knowledge is proposed. As shown in Fig. 12, this framework uses a DNN to handle the complex user association (data module) and a model-based approach for optimal power allocation (knowledge module) in turn. The experimental results verify that the proposed framework performs competitively with the AM algorithm and achieves superior time efficiency, particularly in scenarios with a large number of users.

TABLE V
KNOWLEDGE AND DATA FUSION ARCHITECTURE CONSTRUCTION

Specific integration approach	Areas in wireless networks	Applications	Specific integrated knowledge	Specific knowledge integration approach
Serial mode	Resource management	Resource management problems tackled by multiple sub-problems [174]–[180]	Model-based algorithms	Knowledge modules and data modules respectively tackle different sub-problems.
	Signal processing	Channel estimation [181]; MIMO signal detection [182]; MIMO-OFDM receiver [159], [183], [184]; joint channel estimation and user activity detection [185]	LS-based channel estimator, ZF-based MIMO signal detector	LS estimator/ZF detector is adopted as initial input of data-based channel estimator/signal detector.
Parallel mode	Resource management	Load balancing and TCP congestion control problem [186], [187]	Model-based algorithms	Knowledge modules and data modules are the backup of each other.

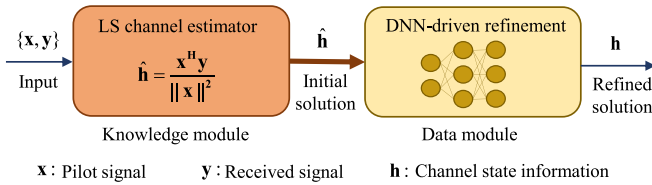

Fig. 13. A refined serial knowledge and data fusion architecture for channel estimation.

For the refinement structure of the serial model, a knowledge and data fusion architecture is proposed for channel estimation in massive MIMO systems [181]. In this architecture, as shown in Fig. 13, the classical LS channel estimator (knowledge module) provides an approximate solution, which is then refined by a denoising convolutional neural network (data module). By combining the strengths of both modules, this architecture outperforms other model-based and data-driven channel estimators.

3) *Related Literature Review on Wireless Resource Management*: In wireless resource management, the mixing structure in the serial model is frequently used to tackle complex multi-dimensional resource allocation problems. This approach breaks down the problems into interdependent sub-problems, assigning each to either a knowledge or data module. By leveraging both theoretical algorithms and data-driven neural networks, the mixing structure has found broad application in areas like multi-cell user association, radio access network (RAN) slicing, and edge computing.

For multi-cell user association problems, as stated in the typical example of the mixed structure, a hybrid framework fusing domain knowledge and DNN is designed in [174], where a deep neural network addresses the user association problem, followed by a convex optimization for the power allocation problem. To realize a practical user association and frequency selection scheme in multi-cell networks, a hybrid algorithm combining convex optimization and user association criteria modification with data-driven cell-specific offsets is presented [175]. For the interference coordination in multi-cell networks, a DNN-based base station muting scheme followed by a rule-based user association algorithm is proposed [176]. To achieve a better trade-off between the model accuracy and the communication cost in federated learning over wireless networks, an iterative knowledge and data fused framework

is proposed [188], where the edge association at the cloud server is tackled by DRL and the resource allocation at the base station is handled by convex optimization.

For emerging topics, to design an optimal radio access network (RAN) slicing policy considering the traffic density and the system cost, a dynamic knowledge and data fused algorithm is proposed [177]. In particular, the formulated constrained RAN slicing problem is decoupled into an outer-layer resource allocation sub-problem and an inner-layer workload distribution sub-problem, which are respectively tackled by data-driven DRL and knowledge-driven convex optimization theory. In [178], a knowledge and data fused algorithm is developed in industrial IoT to improve the long-term accuracy of collaborative DNN, where a knowledge-driven edge computing resource allocation is embedded in a data-driven DRL algorithm deciding the task offloading. As expected, the average service delay is considerably reduced while the task inference accuracy is guaranteed in a high probability. A similar iterative framework involving domain knowledge and neural networks has also been investigated in energy harvesting IoT networks [179] and virtual reality streaming transmission over wireless networks [180].

4) *Related Literature Review on Wireless Signal Processing*: In wireless signal processing, the refinement structure in serial mode is widely used to refine solutions from classical model-based algorithms with idealized assumptions, like LS-based channel estimators and ZF-based MIMO detectors. This approach uses two cascade modules: knowledge modules first generate preliminary solutions, and data modules refine them using real-world data. By leveraging rough solutions as inputs, the need for large training samples is reduced, making this structure particularly effective in various applications, especially the MIMO receiver.

Similar to the typical example of the refinement structure, [182] explores an enhanced MIMO detector that explicitly combines the maximum likelihood detector algorithm with the data-driven deep convolutional neural networks. This hybrid approach significantly lowers the computational complexity typically associated with conventional detectors that rely on the joint distribution of interference signals. Then, knowledge-driven fusion architectures for joint channel estimation and signal detection have been developed for MIMO-OFDM systems [159], [183] and uplink MU-MIMO systems [184]. In these architectures, knowledge of LS-based

channel estimators and ZF-based MIMO detectors is respectively utilized to enhance the performance of the corresponding subsequent data-driven modules. Additionally, the knowledge-driven refinement structure is applied for joint channel estimation and user activity detection in massive machine-type communications [185]. This structure combines model-based sparse signal recovery algorithms, like ADMM and AMP, with data-driven neural networks in a concatenated operation, resulting in improved estimation or detection accuracy with lower computational complexity.

5) *Design Guideline*: For the mixed serial knowledge and data fusion architecture, the main design outlines are given as follows. i) Devise an algorithm that tackles the target problem by splitting it into several interrelated subproblems, which can be addressed separately. ii) Allocate knowledge modules for subproblems with optimal analytical solutions or low-complexity theoretical algorithms, and assign data modules to handle subproblems with high-dimensional or difficult-to-model relationships. ii) Train the final neural network either end-to-end or by optimizing each module individually.

For the refined serial knowledge and data fusion architecture, the main design steps are given in the following. i) Identify a model-based algorithm (i.e., knowledge module) as the initial solution to the target problem. ii) Use the output from the knowledge module as input to a data module for further solution refinement. iii) Train the data module to improve overall performance.

B. Knowledge and Data Fusion in Parallel Mode

1) *Concept*: Parallel mode, shown in Fig. 11(c), the other operation approach of the knowledge and data fusion architecture, allows knowledge and data modules to work concurrently and independently to address the same target problem. The final output is a powerful combination of solutions resulting from both modules, formulated according to specific rules. This mode not only ensures the robustness and reliability of the entire system but also provides a fail-safe by establishing a backup system, where each module can compensate for the potential shortcomings of the other. The parallel operation and mutual backup system are particularly beneficial in unstable or unpredictable communication environments, where one module's output may be less accurate or reliable due to unforeseen changes or disturbances. In essence, it maximizes the advantages of both model-based and data-driven methods, ensuring optimal performance even under less-than-ideal channel conditions.

2) *Typical Example*: For the knowledge and data fusion in parallel mode, we take a teacher-student learning framework proposed in [186], [187] as an example. In this framework, as shown in Fig. 14, a teacher block (knowledge module) represented by explainable theoretical algorithms and a student block (data module) represented by dynamic DRL concurrently and separately solve the targeted problem. After the comparison in the confidence check module, the student neural network mimics the better advice of the teacher block via the reward shaping to improve the solution. The final output combines solutions derived from these two modules,

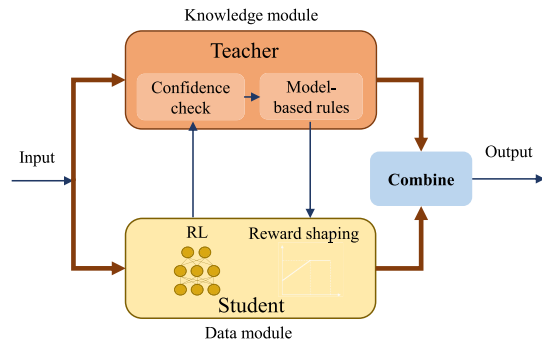

Fig. 14. A parallel knowledge and data fusion architecture to enhance solution robustness.

enhancing the reliability and robustness of solutions. This parallel teacher-student framework has been applied in load balancing and transmission control protocol (TCP) congestion control problems, exhibiting more stable performance in a dynamic environment.

C. Summary and Discussion

Knowledge and data fusion architectures aim to jointly leverage the strengths of expert knowledge and data-driven learning by structurally integrating them within neural networks. This design philosophy is particularly valuable when either knowledge or data alone is insufficient to achieve robust or generalizable performance. Such architectures improve adaptability and reduce data dependency. Two representative designs, i.e., serial and parallel modes, are widely used in wireless systems depending on task characteristics. (1) In the serial mode, knowledge and data modules are connected sequentially. This approach is well-suited for multi-stage tasks or problems with coarse model-based solutions, where knowledge modules and data-driven modules either address distinct but interrelated subproblems or operate sequentially, with knowledge modules providing coarse solutions that are subsequently refined through learning. Serial structures reduce the search space and improve learning efficiency. (2) Parallel mode processes domain knowledge and data streams independently, fusing their outputs through adaptive mechanisms such as confidence weighting. It is particularly effective in uncertain, non-stationary, or partially observable environments. This enhances system robustness and fail-safety.

VII. KNOWLEDGE-DRIVEN LOSS FUNCTION DESIGN

Knowledge-driven loss function involves domain knowledge to re-devise loss functions of neural networks for better learning performance. In addition to conventional label-based terms that are functions between fitted results and true labels, like mean square error and cross-entropy, communication-specific domain knowledge is incorporated in loss functions as additional label-free terms. The involved knowledge here usually comes from methodologies for modeling wireless optimization tasks and a comprehensive understanding of these tasks, represented by mathematical formulas. This integrative approach empowers neural networks to synthesize learning from both

TABLE VI
KNOWLEDGE-DRIVEN LOSS FUNCTION DESIGN

Specific integration approach	Areas in wireless networks	Applications	Specific integrated knowledge	Specific knowledge integration approach
Constraint-specific loss function	Resource management	Primal-dual learning [189] [190] and its applications [62], [191]–[193]	Lagrangian duality techniques to handle constrained problems	Constraints are converted as additional linear penalty terms in the objective function.
		Resource management problems with simple linear summation constraints [194] [92], [99]	Simple linear summation constraint can be converted as widely-adopted activation function in loss functions.	Simple linear constraint is converted as activation function in loss functions to penalize the violations.
Feature-specific loss function	Resource management	Resource management problems addressed by DRL with reward sparsity issues [195]–[198]	Problem features exploited by comprehensive understanding of problems	Feature-specific immediate reward is generated to tackle the reward sparsity problem in DRL.
	Signal processing	CSI feedback [199], [201]	The magnitudes of downlink CSI demonstrate strong correlations with that of uplink CSI.	Magnitude-dependent polar-based loss function is designed [201].
			there exists the underlying joint distribution between CSI phases and CSI magnitude.	Sine mean absolute percentage error is designed as the new loss to capture the joint distribution [202].
Signal detection [201]	Modulation symbol reconstruction loss and user activity detection loss are developed from stochastic signal analysis.	Tailored multi-loss function is designed [203].		

experimental data and theoretical knowledge, thereby enhancing their generalization and adaptive capabilities. In wireless communication networks, the knowledge-driven loss function primarily consists of the constraint-specific loss function and the feature-specific loss function. According to this categorization, the following subsections present the concept of each approach, along with a specific example. Additionally, the relevant literature on knowledge-driven wireless resource management and signal processing will be reviewed, which is outlined in Table VI.

A. Constraint-Specific Loss Function

1) *Concept*: The constraint-specific loss function incorporates knowledge regarding the inherent constraints of optimization problems into loss functions to guide the learning process. Its main purpose is to ensure that the outcomes of neural networks adhere to the practical constraints, which is achieved by adding constraints as label-free loss functions and penalizing any violation of these constraints. This knowledge integration approach provides an effective way to handle wireless network problems with complicated constraints via powerful neural networks.

2) *Typical Example*: A specific example of adopting the constraint-specific loss function in wireless communication networks is primal-dual learning. Consider a general variable optimization problem formulated as

$$\max_{\mathbf{x}} J(\mathbf{x}, \mathbf{h}) \quad \text{s.t.} \quad g_i(\mathbf{x}, \mathbf{h}) \leq 0, \forall i \in \{1, \dots, I\}, \quad (11)$$

where \mathbf{x} and \mathbf{h} are respectively the variable and the environment's status; $J(\cdot)$ and $g_i(\cdot)$ are respectively the objective function and constraints. By introducing a non-negative dual variable λ , problem (11) can be theoretically addressed by Lagrangian duality techniques. This method converts the

constraints as additional linear penalty terms in the objective function and alternatively updates primal variable \mathbf{x} and dual variable λ .

Inspired by knowledge of Lagrangian duality techniques to handle constrained problems, primal-dual learning is proposed in [189]. Specifically, the original variable optimization problem is first reformulated as the following functional optimization problem

$$\max_{\mathbf{f}(\mathbf{h})} J(\mathbf{f}(\mathbf{h}), \mathbf{h}) \quad \text{s.t.} \quad g_i(\mathbf{f}(\mathbf{h}), \mathbf{h}) \leq 0, \forall i \in \{1, \dots, I\}. \quad (12)$$

Here, input \mathbf{h} is mapped to the output \mathbf{x} via function $\mathbf{f}(\cdot)$, casting it as a regression task. Then, following the steps of Lagrangian duality techniques, the primal function is updated via a DNN with a constraint-specific loss function, which is expressed as

$$\mathbf{f}^*(\mathbf{h}) = \underset{\mathbf{f}(\mathbf{h})}{\operatorname{argmax}} J(\mathbf{f}(\mathbf{h}), \mathbf{h}) + \underbrace{\lambda^H \mathbf{g}(\mathbf{f}(\mathbf{h}), \mathbf{h})}_{\text{Constraint-specific term}} \quad (13)$$

with $\mathbf{g}(\cdot) = [g_1(\cdot), \dots, g_I(\cdot)]^H$. Meanwhile, dual variables λ are updated successively with fixed DNN parameters until convergence. It has been formally demonstrated in [190] that the duality gap of statistically constrained optimization problems is small if the DNN model parameters are sufficiently dense.

3) *Related Literature Review on Wireless Resource Management*: In wireless communication networks, resource management problems are always formulated as mathematical optimization problems with several constraints, which are hard to be directly handled by neural networks. To move this obstacle, constraint-specific terms are additionally added to the loss function to penalize the violation of the constraints.

For resource management problems with complicated constraints, primal-dual learning is a widely used DL approach,

as demonstrated in the example. By offering an effective way to manage general complex constraints, this approach has been applied to many wireless resource allocation problems, such as probabilistic constrained power allocation problems for video streaming transmission [191], joint power and bandwidth allocation for ultra-reliable and low-latency communications [192], and power allocation problem with statistical constraints in ad-hoc networks [62]. Furthermore, to avoid the class-imbalanced issue in interference coordination problems with multi-class classification, a min-max loss function is designed and the corresponding neural network is trained via primal-dual learning [193].

For resource management problems with simple linear summation constraints, constraints are approximately converted as activation functions in the loss function. In [194], a novel constraint-specific loss function is developed to tackle a bilevel min-max problem that aims to achieve fairness among data samples. Specifically, the inner maximization problem with linear summation constraint is analytically approximated by a softmax function, and thus the original bilevel problem becomes a minimization problem with smooth compositional loss function, which can be directly optimized via unsupervised learning. In [92], to guarantee the average sum power constraint, the ReLU function is adopted to convert the constraint into an additional term in the loss function. In [99], the knowledge that the weighted sum energy efficiency objective is monotonically non-decreasing concerning the maximum power in constraint is incorporated into the loss function by adding additional hinge loss to penalize violations from monotonicity.

4) *Design Guideline*: To design a constraint-specific loss function, the primary steps are outlined as follows. i) Identify whether the constraints of the target problem are simple linear summation forms. ii) If yes, directly convert such constraints as activation functions in the loss function, based on a comprehensive understanding of the problem. iii) If not, adopt primal-dual learning to linearly add the complex constraints in the loss function.

B. Feature-Specific Loss Function

1) *Concept*: Feature-specific loss function involves domain knowledge, especially the unique features of a problem, to develop tailored loss functions that enhance the learning process. Such knowledge, often derived from a comprehensive understanding of target problems and wireless communication networks, is expressed as mathematical formulas. In deep reinforcement learning, such a customized loss function is often referred to as feature-specific or knowledge-driven reward shaping, serving an analogous role to the loss function in supervised learning by guiding the learning process. It leverages domain knowledge to create immediate rewards or refine existing ones, helping address the challenge of reward sparsity in DRL. Adapting loss functions or reward functions based on feature-specific features can lead to fast convergence and improved results.

2) *Typical Example*: As an example of feature-specific reward shaping, consider the user scheduling problem of a

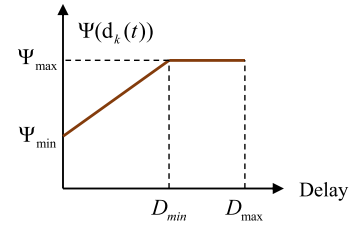

Fig. 15. A potential function for knowledge-driven reward shaping in the user scheduling problem.

downlink communication scenario, where a BS serves K users with queued packets. At each time slot t , users are scheduled based on queue state information (QSI) and CSI to meet strict delay requirements for time-sensitive packets. This long-term scheduling problem is tackled by DRL, where the state is the environment denoted as $S(t) = \{\text{QSI}, \text{CSI}\}$ and the action is the binary user scheduling denoted as $A(t) = \{x_1(t), \dots, x_K(t)\}$. To ensure packets' delay stays within $d_k(t) \in [D_{\min}, D_{\max}]$, the reward is defined as $R(t) = \sum_{k=1}^K r_k(t)$, where

$$r_k(t) = \begin{cases} -\log(\epsilon_k(t)) & x_k(t) = 1 \ \& \ d_k(t) \in [D_{\min}, D_{\max}] \\ 0 & \text{Otherwise,} \end{cases} \quad (14)$$

with $\epsilon_k(t)$ being the decoding error probability. Due to the requirement on delay jitter, BS can receive a positive reward only when the user is scheduled strictly within $d_k(t) \in [D_{\min}, D_{\max}]$. When $d_k(t) < D_{\min}$, the instantaneous reward is 0 regardless of the schedule. This leads to a severe reward sparsity issue, making it challenging for DRL to explore correct actions without environmental feedback.

To handle this issue, feature-specific reward shaping involving unique problem characteristics is adopted in [195] to generate non-zero instantaneous feedback in each slot. Specifically, the target scheduling policy is only to schedule users with $d_k(t) \in [D_{\min}, D_{\max}]$. Via a comprehensive understanding of this target policy and the considered scheduling problem, when $d_k(t) < D_{\min}$, a linearly increasing non-zero reward can guide BS to gradually improve the scheduling probability until $d_k(t)$ falls in its target zone. Informed by this knowledge, a potential function $\Psi(d_k(t))$, as illustrated in Fig. 15, is defined and a shaped reward of user k is accordingly reformulated as

$$\hat{r}_k(t) = r_k(t) - \Psi(d_k(t)) + \gamma\Psi(d_k(t+1)), \quad (15)$$

where γ is a fixed parameter close to 1. When $d_k(t) < D_{\min}$, $r_k(t) = 0$ no matter whether the user is scheduled or not. If the user is not scheduled, then $d_k(t+1) = d_k(t)$ and $-\Psi(d_k(t)) + \gamma\Psi(d_k(t+1)) > 0$, generating a positive reward. If the user is scheduled, then $d_k(t+1) < d_k(t)$ and $-\Psi(d_k(t)) + \gamma\Psi(d_k(t+1)) < 0$, generating a negative reward. Therefore, the feedback of the feature-specific reward is summarized as

$$\hat{r}_k(t) \begin{cases} \gg 0 & x_k(t) = 1 \ \& \ d_k(t) \in [D_{\min}, D_{\max}] \\ > 0 & x_k(t) = 0 \ \& \ d_k(t) < D_{\min} \\ < 0 & x_k(t) = 1 \ \& \ d_k(t) < D_{\min}. \end{cases} \quad (16)$$

With knowledge-involved reshaping, as verified by experiment results in [195], the non-zero instantaneous reward guides the learning algorithm toward desirable behaviors more efficiently, ultimately improving both learning speed and policy quality in dynamic environments.

3) *Related Literature Review on Wireless Resource Management*: In wireless resource management, feature-specific loss functions, also known as feature-specific reward shaping, are widely used in reinforcement learning. By leveraging domain knowledge to generate timely rewards or refine them, this approach addresses reward sparsity, accelerates training speed, and improves policy quality. As a result, feature-specific loss functions have been initially adopted in DRL-based wireless resource management.

For time-sensitive traffic with strict requirements on delay, in addition to the stated example, the knowledge-involved instantaneous reward is also generated in [196]. Here, the large action space of the fine-grained microservice orchestration problem is decomposed into several intermediate low-dimensional actions in small decision epochs and the corresponding intermediate mathematical rewards are artificially designed with the understanding of the target policy to improve the learning efficiency. For packet-routing problems in ad-hoc networks with sparse end-to-end rewards, the knowledge concerning the system's dynamics is exploited to generate an intermediate reward for each hop to boost the learning speed [197]. For resource allocation and trajectory design in UAV-assisted cellular networks, to make the long-term fairness throughput decomposable in each epoch, an entropy-like fairness indicator is introduced to generate a real-time reward for fairness throughput [198]. To improve the robustness of DRL, a teacher-student framework is proposed in [186], [187], where the knowledge regarding theoretical algorithmic rules in the teacher network is injected into the DRL-based student network by incorporating the teaching data into the reward of DRL. Experiment results show that the proposed framework achieves more stable performance in a dynamic environment when applied in adaptive video streaming, load balancing and TCP congestion control.

4) *Related Literature Review on Wireless Signal Processing*: In wireless signal processing, feature-specific loss functions fully leverage domain knowledge concerning unique problem characteristics or a comprehensive understanding of the problem to enhance the supervised learning process. These features are typically expressed as mathematical formulas, allowing the loss functions to be tailored accordingly. Due to their effectiveness in improving learning performance, feature-specific loss functions have been adopted across various signal processing problems, such as CSI feedback and signal detection.

In frequency-division duplexing (FDD) systems, it is observed that the magnitudes of downlink CSI demonstrate strong correlations with other CSIs, such as uplink CSI and adjacent users' CSI, due to similar environmental propagation characteristics. However, the phases of different CSIs are highly sensitive to even minor changes in frequency and location. To leverage this side information in the intelligent downlink CSI feedback, dual feedback frameworks assisted

by correlated CSI magnitudes are constructed, wherein magnitudes and phases of downlink CSI are encoded and recovered separately. Within these frameworks, a novel magnitude-dependent polar-based loss function is introduced in [199], inspired by expert knowledge that phases associated with larger CSI magnitudes play a more vital role in CSI recovery. This customized loss function compresses significant CSI phases based on the corresponding CSI magnitudes, resulting in more precise feedback and improved recovery of CSI in massive MIMO systems. To further enhance the CSI feedback efficiency, a DL architecture for joint magnitude and phase encoding with a modified loss function is proposed in [200]. The authors introduced the sine mean absolute percentage error as the new loss function, specially designed to capture the underlying joint distribution between CSI phases and CSI magnitude. For intelligent signal detection in grant-free scenarios with massive devices, a tailored multi-loss function is designed in [201]. This function combines weighted modulation symbol reconstruction loss with user activity detection loss, both of which are developed from stochastic signal analysis. Owing to embedding theoretical knowledge into the loss function, the proposed approach achieves significant reliability gain.

5) *Design Guideline*: Key procedures to design a feature-specific loss function are listed as follows. i) Perform a comprehensive analysis of the target problem to identify unique features (i.e., knowledge) that can effectively reshape the loss function. ii) Incorporate these identified features into the formulation of a tailored loss function, such as knowledge-inspired immediate reward generation. iii) Utilize the newly designed loss function to steer and enhance the learning process of the neural network.

C. Summary and Discussion

Knowledge-driven loss function design embeds domain knowledge directly into the training objective, offering a flexible way to steer neural network optimization. This approach is particularly effective for wireless tasks with complex constraints or limited supervision, where standard losses are insufficient to capture such requirements. Involving knowledge-driven label-free terms leads to improved performance and training efficiency, especially in constrained or weakly supervised settings. Two major types are constraint-specific and feature-specific loss functions. (1) Constraint-specific loss functions are designed for tasks with explicit complex constraints, such as power constraints, interference constraints or QoS requirements. Domain knowledge is expressed mathematically (e.g., via Lagrangian penalty terms) and integrated into the loss to penalize constraint violations, thereby ensuring that outputs remain feasible without requiring post-processing or projection. (2) Feature-specific loss functions apply to tasks where characteristics, such as sparsity and periodicity, are critical to performance but not captured by labels. These features are represented via custom loss terms, e.g., sparsity-inducing norms, which guide the network toward representations aligned with critical domain properties and enhance training efficiency. This is

useful in weakly supervised settings like reward shaping in DRL.

VIII. KNOWLEDGE-DRIVEN HYPERPARAMETER CONFIGURATION

With the designed neural network models and loss functions, hyperparameters, such as the number of layers, the initialized weights, the learning rates, and so on, also significantly impact the performance and the training process of neural networks. Traditionally, hyperparameters are predetermined empirically or through exhaustive searches, which consume substantial computational resources and incur high training costs. The approach of knowledge-driven hyperparameter leverages domain knowledge to predetermine a subset of these settings, thereby potentially speeding up the training process and enhancing the model's robustness. In wireless communication networks, the domain knowledge involved in the hyperparameter configuration generally stems from scientific knowledge and unique features of wireless networks, respectively conveyed as mathematical formulas and narrative propositions. Based on the existing literature review, knowledge-driven hyperparameter configuration in wireless communication networks primarily includes the model-related hyperparameter setting and the algorithm-related hyperparameter setting. Following this categorization, the subsequent subsections introduce the concepts and provide examples for each approach, along with a review of related literature on wireless resource management and signal processing. The key details from the literature review are summarized in Table VII.

A. Model-Related Hyperparameter Setting

1) *Concept*: In the knowledge-driven model-related hyperparameter setting of neural networks, domain knowledge is involved in deciding the input and output in neural networks as well as the width and depth of neural networks, and so on. Such knowledge usually stems from theoretical solutions to wireless network optimization or a deep understanding of target problems, expressed in mathematical formulas or narrative propositions. The input and output design in wireless communication networks includes the incorporation of new inputs and the dimensionality reduction of either inputs or outputs in neural networks. The new input incorporation is adopting expert knowledge to identify vital information for specific tasks and adding it as additional input to neural networks to enhance the learning performance. The dimensionality reduction involves scientific knowledge to equivalently transform the original learning tasks into new learning tasks with fewer inputs and outputs, thereby accelerating the convergence in the training process. This approach is particularly useful in wireless resource management problems handled by deep reinforcement learning, which theoretically reshapes and simplifies the state (i.e., input) and action (i.e., output) spaces to circumvent the “curse of dimensionality” issue. Furthermore, the width and depth of neural networks can also be tailored for specific tasks.

2) *Typical Example*: A typical example of the model-related hyperparameter setting is uplink CSI-aided downlink

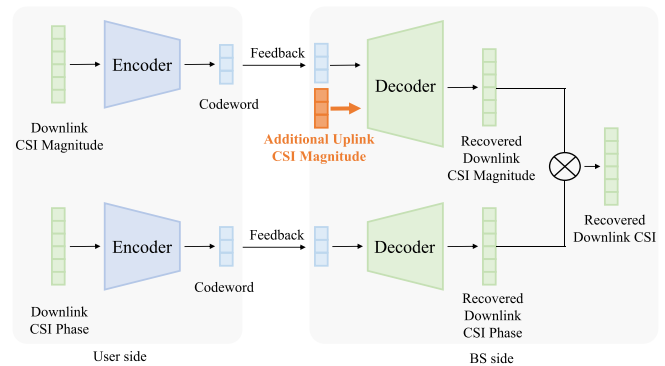

Fig. 16. Uplink CSI aided downlink CSI feedback in massive MIMO FDD systems.

CSI feedback in massive MIMO FDD systems. Here, downlink CSI at the BS is obtained via user feedback, but excessive CSI overhead may consume too much bandwidth and degrade spectrum efficiency. To address this, an encoder-decoder framework is commonly used to compress CSI at the user end and recover it at the BS intelligently. Additionally, the bidirectional reciprocity of the FDD channel, as highlighted in [203], reveals a strong correlation between uplink and downlink CSI magnitudes, stemming from the shared signal propagation environment. This knowledge motivates the use of uplink CSI to improve downlink CSI recovery. Consequently, innovative encoder-decoder architectures for downlink CSI feedback in FDD systems have been developed in [199], [200], [203], as shown in Fig. 16, where the magnitude of uplink CSI is integrated as an input to enhance downlink CSI recovery. Simulation results confirm that this addition significantly improves the channel recovery precision.

3) *Related Literature Review on Wireless Resource Management*: In resource management of wireless communication networks, the configuration of model-related hyperparameters is dominated by the knowledge-driven inputs and outputs design of neural networks, which focuses on incorporating domain knowledge to theoretically refine neural networks' inputs and outputs. This approach finds its most significant application in DRL-based resource management problems, where the action space and decision variables are high-dimensional. By employing scientific knowledge, like the analytical solution for a part of actions or theoretically equivalent problem simplification, complex resource management problems can be transformed into more tractable forms with simplified states and actions. Consequently, the dimensionality of the state and action spaces is substantially reduced, effectively mitigating the “curse of dimensionality” and speeding up the training process.

Specifically, in [195], a knowledge-aided DRL for downlink scheduling is proposed, where a joint user schedule and resource block allocation scheme is conducted considering the channel state information and the queue state. To address the issue of the large action space, the number of allocated resource blocks is directly calculated by the theoretical formula of decoding error probability if a user is selected, and the BS only needs to determine which users to schedule.

TABLE VII
KNOWLEDGE-DRIVEN HYPERPARAMETER CONFIGURATION

Specific integration approach	Areas in wireless networks	Applications	Specific integrated knowledge	Specific knowledge integration approach
Model-based hyperparameter setting	Resource management	Resource management problems addressed by DRL with curse of dimensionality [91], [195], [196], [205]	A part of actions can be directly derived by theoretical solutions	Theoretical solutions are adopted to reduce the action space in DRL.
	Signal processing	CSI feedback [199], [200] [203]–[205]	There is a significant correlation between uplink and downlink channel magnitudes.	The magnitude of uplink CSI is incorporated as input to aid downlink CSI recovery [201], [202], [206].
			The size of kernels in CNN is better to adapt to the sparsity of wireless channels.	Convolutional layers with larger [207] or varying kernel sizes [208] are designed.
Algorithm-related hyperparameter setting	Resource management	Multi-user power allocation [85], [206]	Permutation equivalence property widely exists in wireless tasks.	PE is exploited to design parameter sharing DNNs.
		Primal-dual learning [189], [190] and its applications [62], [191], [192]	Lagrangian duality techniques to handle constrained problems	Weight coefficients in loss functions is inspired by multipliers in Lagrangian dual techniques.

With the involvement of knowledge regarding the theoretically derived number of allocated resource blocks, the action space of the scheduling problem is considerably reduced and the convergence rate becomes extremely faster. In [91], [202], a predictive power allocation policy for energy-efficient video streaming is devised with the assistance of theoretical knowledge. In particular, by exploiting the knowledge regarding the distribution of small-scale fading and deriving the optimal closed-form power allocation policy for any given average data rate, the state and action are respectively designed as low-varying average channel gain and average data rate, instead of the instantaneous channel gain and fast-varying power allocation. This equivalent transformation significantly reduces the decision frequency and hence avoids the huge signaling overhead. Furthermore, by decomposing the system's dynamics into known parts with theoretical state transition probability and unknown parts, the post-decision state is involved in DRL and the high-dimensional action-value function is estimated via a low-dimensional function, which considerably reduces the number of learned parameters. To reduce the high dimensional action space for online microservice orchestration in IoT networks, the large action space in each timestamp is decoupled into several small decision epochs with each epoch taking two simple intermediate actions and returning corresponding smaller rewards [196], which also solves the reward sparsity problem and greatly improves learning efficiency.

4) *Related Literature Review on Wireless Signal Processing*: In wireless signal processing, domain knowledge regarding unique features revealed by expertise and a throughout understanding of tasks can be involved to guide the setting of hyperparameters. This approach not only improves the interpretability of neural networks but also has the potential to produce superior outcomes. Consequently, model-based hyperparameter settings informed by domain knowledge are increasingly being applied in CSI feedback.

In addition to incorporating new input for intelligent downlink CSI feedback in FDD systems, as described in the example, CNN kernel sizes are also adjusted to better suit CSI feedback tasks. Specifically, CsiNet in [204] adopts a

7×7 CNN kernel to handle the CSI sparsity in the angular-delay domain, as larger kernels are advantageous for sparser areas. Besides, CSI sparsity varies not only across different scenarios but also within different areas of a single CSI sample. Motivated by this knowledge, the CRNet architecture, proposed in [205], employs convolutional layers with varying kernel sizes, providing multiple resolutions to improve CSI feedback effectiveness.

5) *Design Guideline*: Major steps to configure model-related hyperparameters are given in the following. i) Examine the target problem in-depth to uncover key insights, such as equivalent problem simplification or important auxiliary information, that motivate the optimal configuration of the neural network, including input and output dimensions. ii) Use the gained insights to fine-tune the neural network size and architecture accordingly. iii) Proceed with training the adjusted neural network to ensure effective learning and performance.

B. Algorithm-Related Hyperparameter Setting

1) *Concept*: In the knowledge-driven algorithm-related hyperparameter setting of neural networks, prior knowledge is involved to determine and tune the initial parameters of neural networks, the weighted coefficients in loss functions, the learning rates and so on. The involved knowledge often originates from theoretical solutions to wireless network optimization or a deep understanding of target problems, typically formulated in mathematical formulas or narrative propositions. With the guidance of such knowledge, these hyperparameters are somewhat interpretable, thereby speeding up the training process and yielding robust performance.

2) *Typical Example*: In signal processing problems solved through algorithm unfolding [17], the initial parameters of unfolded neural networks can be inherited from theoretical iterative algorithms, known as domain knowledge. This approach achieves a significant improvement over traditional random initialization methods. It ensures that the neural networks have a solid foundation based on theoretical understanding, making the training process more stable and the model more reliable from the outset.

3) *Related Literature Review on Wireless Resource Management*: According to the relevant literature, algorithm-related hyperparameter settings in wireless resource management, informed by domain knowledge, include weight parameters in neurons and the weighted coefficients in loss functions. By leveraging properties of target problems, knowledge-driven hyperparameter design enhances training efficiency and has been effectively applied in tasks such as power allocation problems.

In wireless resource management, one kind of algorithm-related hyperparameter setting is the knowledge-driven weight parameter design in neural networks. This design is pivotal because the principal goal of neural networks is to learn an optimal set of weight parameters that link neurons across successive layers, ultimately forming a mapping converting input features to desired outputs. With the scale of neural networks increasing, the number of weight parameters to be determined becomes huge, imposing a substantial computational burden and prohibitively long training time. To circumvent this challenge in wireless resource management, domain knowledge concerning the intrinsic properties of wireless tasks can be leveraged to significantly reduce the weight parameters. Specifically, a widely observed property known as PE indicates that the output ordering changes with the input order, while the values of corresponding outputs remain unchanged. Leveraging this knowledge, J. Guo et al. identified a special weight matrix structure in MLPs applicable to a broad range of wireless tasks [206]. That is, for tasks with the PE property, the weight parameters of MLP related to each PE unit are identical. Thus, a parameter-sharing scheme is proposed to considerably reduce the number of weight parameters to be determined, thereby decreasing the training complexity. Considering the same property, C. Sun et al. found that ranking PE units in descending order based on their magnitudes can further reduce the required training samples [85].

In addition to the weight parameter design in neural network models, for wireless resource management problems addressed by primal-dual learning, the weighted coefficients in constraint-specific loss functions are also inspired by theoretical methods. To elaborate, in primal-dual learning, non-negative dual variables, i.e., the weighted coefficients λ in (13), are introduced to convert the constraints of the problem as additional linear penalty terms in the loss function. This strategy is informed by Lagrangian duality techniques, which provide a theoretical basis for both the learning of the neural network with the newly defined loss function and the subsequent theoretical updates to the weighted coefficients. As obeying the basic mathematical principle of Lagrangian duality techniques, the adjustment of weighted coefficients in primal-dual learning is precise and meaningful, contributing to better learning performance in dealing with constrained resource management problems [190]. Therefore, this approach has been applied in probabilistic constrained power allocation for video streaming transmission [191], joint power and bandwidth allocation for ultra-reliable and low-latency communications [192], and power allocation with statistical constraints in ad-hoc networks [62].

4) *Design Guideline*: Key steps for configuring algorithm-related hyperparameters are outlined in the following. i) Investigate the target problem to uncover insights that guide the choice of critical hyperparameters like initial weights and learning rates. ii) Use the discovered insights to appropriately configure the neural network's related hyperparameters. iii) Train the neural network with the configured settings.

C. Summary and Discussion

Knowledge-driven hyperparameter configuration incorporates communication-specific insights to configure model-related and algorithm-related parameters. Compared with traditional trial-and-error tuning, this approach helps improve convergence efficiency, reduce sample complexity, and enhance overall performance. Two representative approaches are model-related and algorithm-related hyperparameter configurations. (1) Model-related hyperparameter setting is best suited for high-dimensional tasks where theoretical problem transformation or discovered auxiliary knowledge can guide structural simplifications, like network width, depth, input and output. This helps mitigate the “curse of dimensionality” and significantly accelerates convergence while boosting model accuracy. (2) Algorithm-related hyperparameter setting is effective for tasks with theoretical underpinnings or empirical insights. By initializing parameters, weighting loss terms, or tuning learning rates based on domain principles (e.g., from classical algorithms or primal-dual optimization), this approach improves training stability and solution quality.

IX. CHALLENGES AND FUTURE DIRECTIONS

By embedding domain knowledge into neural networks, as the literature reviewed in this survey indicates, knowledge-driven DL methods can effectively combine the interpretability of model-based theoretical approaches with powerful universal approximation capabilities and rapid online inference of neural networks. Despite these attractive benefits, substantial advancements are still required to enhance current techniques for reliable intelligent wireless network optimization in complicated 6G networks. To broaden the scope of its applications in future wireless communication systems, this section will explore several challenges and potential future research directions.

A. Knowledge-Driven DL to Handle Complex Constraints

Neural networks are originally developed for NLP and CV, which typically involve no constraints. However, in the field of wireless communications, both resource management and signal processing tasks generally have multiple complex constraints, such as the minimal rate requirement, the maximum tolerable delay, the maximum allowable sum power, and so on. Mathematically, these constraints in wireless networks often take the form of quadratic, logarithmic, and fractional functions and other complicated non-convex functions. In the era of 5G beyond and 6G, due to the diversified QoS demands, highly dynamic communication typologies, extensive coverage areas and multi-dimensional heterogeneous resource orchestration,

the constraints tend to be more intricate [207]. To address these challenges, some cutting-edge knowledge-driven DL approaches have attempted to embed simple constraints like linear constraints or those with clear geometric interpretations as the additional output layers of neural networks, aiming to project the outcomes to feasible regions. While significant advancements have been made, current knowledge-driven DL techniques primarily succeed in problems with relatively simple constraints. The quest to develop reliable knowledge-driven DL approaches that can rigorously meet any nonlinear constraint remains a significant and ongoing challenge, particularly in the realm of wireless network optimization with stringent QoS requirements.

B. Interpretability and Performance Guarantees of Knowledge-Driven DL

While recent data-driven DL methods have shown remarkable performance in the field of NLP and CV, their practical application in wireless network optimization is still limited due to their “closed-box” nature and poor theoretical foundation. By embedding explainable communication-specific domain knowledge, especially theoretical knowledge that is both explainable and analytically rigorous, into neural networks, knowledge-driven DL can significantly enhance the interpretability of neural networks. A particularly promising knowledge-driven DL method is the deep unfolding approach, which designs customized neural networks based on the structure and procedures of iterative algorithms. The resulting knowledge-embedded neural networks inherit both the fast online inference of neural networks and the interpretability of model-based algorithms. Nonetheless, a comprehensive understanding of the mechanism of knowledge-driven DL is still unattainable. Additionally, unlike model-based approaches with analytical tractability and robust performance, knowledge-driven DL struggles to offer rigorous performance guarantees. Consequently, to effectively implement knowledge-driven DL in scenarios requiring highly reliable QoS, such as industrial Internet of Things environments, more comprehensive theoretical research into the inner workings of neural networks is required. Such understanding will not only clarify the behavior of intelligent wireless communication networks but also point out potential directions for enhancing network performance.

C. Knowledge-Driven Generative AI and Large Language Models for Wireless Networks

Recently, generative AI [208], [209], [210], [211], represented by large language models (LLMs) and ChatGPT [212], has achieved extraordinary breakthroughs in various domains, particularly in NLP tasks such as conversations, reasoning, and text generation. With their ability to capture nuanced patterns and contextual relationships via billions of parameters pre-trained on massive datasets, these models have demonstrated remarkable capabilities in understanding and generating human-like text. Although the deployment of LLMs often brings computational and storage overhead, emerging techniques such as cloud-edge collaborative frameworks [213] and distributed inference mechanisms [214] have shown

promise in alleviating these burdens. Given these advances, it is worthwhile to unlock the potential of LLMs in addressing the sophisticated optimization problems in future 6G wireless networks. However, several limitations exist when applying LLMs in wireless network optimization. One significant issue of LLMs is their tendency to hallucinate, producing outputs that resemble human responses but lack factual accuracy [215], [216]. This is because LLMs generate responses by predicting the next word in a sequence based on statistical patterns in the training data, rather than through an understanding of the real world. As a result, LLMs may create information that seems credible but is actually incorrect, often violating physical laws and real-world constraints when addressing complex problems in wireless networks. This discrepancy between LLM outputs and actual constraints renders LLM-generated solutions unreliable for optimizing wireless networks. Another major issue is that most LLMs are initially designed to accept plain textual data as input, which hinders their ability to directly process and understand other data modalities. In wireless networks, inputs for networking algorithms come in various forms, such as time-series network traffic and graph-structured network topology data. These forms are significantly different from plain text, creating a fundamental mismatch. Consequently, LLMs struggle to effectively interpret and process the diverse and complex inputs required for networking tasks.

To tackle these limitations, it is crucial to empower LLMs with communication-specific domain knowledge, adapting them to optimize wireless systems effectively. This makes knowledge-driven LLMs a promising and emerging research direction. To align the outcomes of LLMs with the physical realities and practical constraints of wireless networks, one potential solution is fine-tuning LLMs using specialized datasets and tailored loss functions. A notable example is a specialized dataset containing 10,000 questions and answers on wireless networks, as described in [217]. During the fine-tuning phase, customized loss functions can be designed to incorporate human feedback, providing iterative improvements and ensuring that the LLM’s outputs align with expert knowledge and practical requirements. Given that tuning LLMs with billions of parameters is both time-consuming and computationally intensive, another effective approach is to embed knowledge-inspired neural network modules either before or after the LLMs and train only these modules during fine-tuning [218]. Pre-located modules can act as multimodal encoders to handle the diverse input information in networking tasks effectively, while post-located modules can generate accurate and contextually appropriate responses for specific networking scenarios. While these solutions offer promising directions, extensive pioneering research is still needed to design reliable knowledge-driven LLMs for various network tasks, balancing computational cost and performance accuracy.

D. Practical Application and Standardization of Neural Networks in Wireless Networks

Up to now, the majority of the literature on both knowledge-driven and data-driven DL methods in wireless networks is predominantly within the realm of academic research, focusing

on exploring all possible advantages these technologies may offer. For their successful and seamless deployment in real-world wireless networks, several key factors need to be taken into account. The primary concern is the compatibility of neural networks with existing wireless communication protocols and architectures. Wireless networks are complex systems composed of various technologies that have evolved over decades. Integrating neural networks involves ensuring that they can work within the constraints of current network protocols, potentially requiring adjustments in both wireless network architectures and neural network deployments. Furthermore, the practical hardware limitations of mobile devices should be considered. Mobile devices, particularly those in mobile and IoT contexts, are often constrained by battery life. Neural networks, especially DL models, are typically resource-intensive. Optimizing these models to operate with minimal energy consumption while maintaining performance is crucial for their sustainability and practicality in wireless applications. Thirdly, the collaboration of neural network models across different manufacturers, involving secure data sharing, joint model training and inference, is an important factor to consider when applying neural networks in the field of wireless communications.

To advance the real-world deployment of intelligent wireless networks, both the 3GPP and IEEE 802.11bn have initiated relevant standardization efforts. In its 18th release, 3GPP introduced a study item focused on the use of AI for the new radio air interface, which explores the integration of AI at the physical layer, particularly for tasks such as localization, beam management, and CSI feedback [219]. Similarly, IEEE 802.11bn is exploring AI applications in distributed channel access, seamless roaming, and multiple access point coordination [220]. While these standardization efforts attempt to tackle the practical issues previously discussed, the process is still in its infancy stage, with only a limited number of use cases thoroughly investigated to date. For the successful realization of intelligent wireless networks, extensive work is needed in areas like developing a universal AI framework, establishing user-network collaboration mechanisms, and managing the AI model lifecycle including model activation, deactivation, monitoring, switching, and updating. Along with these functional modules, it is crucial to develop related signaling and network protocols that will support data collection, model inference, and performance monitoring.

X. CONCLUSION

In this paper, a comprehensive overview of knowledge-driven DL in wireless networks has been presented, focusing on the innovative angle of knowledge integration. To begin with, a clear definition of domain knowledge specific to wireless networks has been provided, and the various types and representations of knowledge that can be incorporated into neural networks have been offered. Additionally, a novel classification framework for knowledge integration approaches within wireless networks has been proposed, which includes the incorporation of domain knowledge into neural network model selection, neural network model customization, architecture

construction for knowledge and data fusion, loss function design, and hyperparameter configuration. According to this taxonomy, an in-depth review of the literature on knowledge-driven resource allocation and signal processing has been conducted. Finally, several challenges and future directions have been discussed. We aim for this survey to assist researchers in identifying the appropriate methods to leverage prior knowledge for the design of 6G intelligent communications.

REFERENCES

- [1] ITU-R. "Framework and overall objectives of the future development of IMT for 2030 and beyond." Accessed: Jun. 2023. [Online]. Available: <https://www.itu.int/en/ITU-R/study-groups/rsg5/rwp5d/imt-2030/Pages/default.aspx>
- [2] X. Shen et al., "Toward immersive communications in 6G," *Front. Comput. Sci.*, vol. 4, pp. 168–168, Nov. 2023.
- [3] J. Kang et al., "Blockchain-based pseudonym management for vehicle twin migrations in vehicular edge metaverse," *IEEE Internet Things J.*, vol. 11, no. 21, pp. 34254–34269, Nov. 2024.
- [4] G. Munz, S. Pfletschinger, and J. Speidel, "An efficient water-filling algorithm for multiple access OFDM," in *Proc. IEEE Global Telecommun. Conf. (GLOBECOM)*, Taipei, China, Nov. 2002, pp. 681–685.
- [5] A. Zappone, M. D. Renzo, M. Debbah, T. T. Lam, and X. Qian, "Model-aided wireless artificial intelligence: Embedding expert knowledge in deep neural networks for wireless system optimization," *IEEE Veh. Technol. Mag.*, vol. 14, no. 3, pp. 60–69, Sep. 2019.
- [6] X. Shen, J. Gao, W. Wu, M. Li, C. Zhou, and W. Zhuang, "Holistic network virtualization and pervasive network intelligence for 6G," *IEEE Commun. Surveys Tuts.*, vol. 24, no. 1, pp. 1–30, 1st Quart., 2021.
- [7] X. Shen et al., "AI-assisted network-slicing based next-generation wireless networks," *IEEE Open J. Veh. Technol.*, vol. 1, pp. 45–66, 2020.
- [8] J. Guo, C.-K. Wen, S. Jin, and G. Y. Li, "Overview of deep learning-based CSI feedback in massive MIMO systems," *IEEE Trans. Commun.*, vol. 70, no. 12, pp. 8017–8045, Dec. 2022.
- [9] T. Wang, C.-K. Wen, H. Wang, F. Gao, T. Jiang, and S. Jin, "Deep learning for wireless physical layer: Opportunities and challenges," *China Commun.*, vol. 14, no. 11, pp. 92–111, Nov. 2017.
- [10] H. Kim, S. Oh, and P. Viswanath, "Physical layer communication via deep learning," *IEEE J. Sel. Areas. Inf. Theory*, vol. 1, no. 1, pp. 5–18, May 2020.
- [11] G. Cerar, H. Yetgin, M. Mohorcic, and C. Fortuna, "Machine learning for wireless link quality estimation: A survey," *IEEE Commun. Surveys Tuts.*, vol. 23, no. 2, pp. 696–728, 2nd Quart., 2021.
- [12] J. Zhang and K. B. Letaief, "Mobile edge intelligence and computing for the Internet of Vehicles," *Proc. IEEE*, vol. 108, no. 2, pp. 246–261, Feb. 2020.
- [13] S. He et al., "An overview on the application of graph neural networks in wireless networks," *IEEE Open J. Commun. Soc.*, vol. 2, pp. 2547–2565, 2021.
- [14] R. Sun, N. Cheng, C. Li, F. Chen, and W. Chen, "Knowledge-driven deep learning paradigms for wireless network optimization in 6G," *IEEE Netw.*, vol. 38, no. 2, pp. 70–78, Mar. 2024.
- [15] C. O. Retzlaff et al., "Post-hoc vs ante-hoc explanations: XAI design guidelines for data scientists," *Cogn. Syst. Res.*, vol. 86, Aug. 2024, Art. no. 101243.
- [16] A. Sarkar, D. Vijaykeerthy, A. Sarkar, and V. N. Balasubramanian, "A framework for learning ante-hoc explainable models via concepts," in *Proc. IEEE/CVF Conf. Comput. Vis. Pattern Recognit. (CVPR)*, New Orleans, LA, USA, Jun. 2022, pp. 10286–10295.
- [17] V. Monga, Y. Li, and Y. C. Eldar, "Algorithm unrolling: Interpretable, efficient deep learning for signal and image processing," *IEEE Signal Process. Mag.*, vol. 38, no. 2, pp. 18–44, Mar. 2021.
- [18] H. Yang et al., "Knowledge-driven resource allocation for wireless networks: A WMMSE unrolled graph neural network approach," *IEEE Internet Things J.*, vol. 11, no. 10, pp. 18902–18916, Feb. 2024.
- [19] L. von Rueden et al., "Informed machine learning—A taxonomy and survey of integrating prior knowledge into learning systems," *IEEE Trans. Knowl. Data Eng.*, vol. 35, no. 1, pp. 614–633, Jan. 2023.

- [20] C. Meng, S. Seo, D. Cao, S. Griesemer, and Y. Liu, "When physics meets machine learning: A survey of physics-informed machine learning," *Mach. Learn. Comput. Sci. Eng.*, vol. 1, p. 20, Mar. 2022.
- [21] C. She et al., "A tutorial on ultrareliable and low-latency communications in 6G: Integrating domain knowledge into deep learning," *Proc. IEEE*, vol. 109, no. 3, pp. 204–246, Mar. 2021.
- [22] Y. Shi et al., "Machine learning for large-scale optimization in 6G wireless networks," *IEEE Commun. Surveys Tuts.*, vol. 25, no. 4, pp. 2088–2132, 4th Quart., 2023.
- [23] N. Shlezinger, J. Whang, Y. C. Eldar, and A. G. Dimakis, "Model-based deep learning," *Proc. IEEE*, vol. 111, no. 5, pp. 465–499, Mar. 2023.
- [24] N. P. White, *Plato on Knowledge and Reality*. London, U.K.: Hackett, 1976.
- [25] R. T. Allen, "The philosophy of Michael Polanyi and its significance for education," *J. Philos. Educ.*, vol. 12, no. 1, pp. 167–178, Jul. 1978.
- [26] S. Grimm, "Knowledge representation and ontologies," in *Scientific Data Mining and Knowledge Discovery: Principles and Foundations*. Cham, Switzerland: Springer, 2009, pp. 111–137.
- [27] S. Ji, S. Pan, E. Cambria, P. Martinen, and S. Y. Philip, "A survey on knowledge graphs: Representation, acquisition, and applications," *IEEE Trans. Neural Netw. Learn. Syst.*, vol. 33, no. 2, pp. 494–514, Feb. 2022.
- [28] K. Qu, W. Zhuang, Q. Ye, W. Wu, and X. Shen, "Model-assisted learning for adaptive cooperative perception of connected autonomous vehicles," *IEEE Trans. Wireless Commun.*, vol. 23, no. 8, pp. 8820–8835, Aug. 2024.
- [29] White-paper. "Building autonomous driving telecom networks, white paper for the Huawei SoftCOM AI solution." Accessed: Apr. 2019. [Online]. Available: <https://www.huawei.com/en/huaweitech/industry-insights/technology/naie/imaster-naie-whitepaper>
- [30] C. Zhou, J. Gao, M. Li, N. Cheng, X. Shen, and W. Zhuang, "Digital twin-based 3-D map management for edge-assisted device pose tracking in mobile AR," *IEEE Internet Things J.*, vol. 11, no. 10, pp. 17812–17826, May 2024.
- [31] M. Li, J. Gao, C. Zhou, X. Shen, and W. Zhuang, "User dynamics-aware edge caching and computing for mobile virtual reality," *IEEE J. Sel. Topics Signal Process.*, vol. 17, no. 5, pp. 1131–1146, Sep. 2023.
- [32] T. Wu et al., "Explainable AI security: Exploring robustness of graph neural networks to adversarial attacks," 2024, *arXiv:2406.13920*.
- [33] Y. Hua, Z. Zhao, R. Li, X. Chen, Z. Liu, and H. Zhang, "Deep learning with long short-term memory for time series prediction," *IEEE Commun. Mag.*, vol. 57, no. 6, pp. 114–119, Jun. 2019.
- [34] Z. Zhang, F. Li, X. Chu, Y. Fang, and J. Zhang, "dmTP: A deep Meta-learning based framework for mobile traffic prediction," *IEEE Wireless Commun.*, vol. 28, no. 5, pp. 110–117, Oct. 2021.
- [35] A. Azari, F. Salehi, P. Papapetrou, and C. Cavdar, "Energy and resource efficiency by user traffic prediction and classification in cellular networks," *IEEE Trans. Green Commun. Netw.*, vol. 6, no. 2, pp. 1082–1095, Jun. 2022.
- [36] J. Guo, Y. Chen, J. Zhu, and S. Zhang, "Can we achieve better wireless traffic prediction accuracy?" *IEEE Commun. Mag.*, vol. 59, no. 8, pp. 58–63, Aug. 2021.
- [37] D. E. Ruíz-Guirola, C. A. Rodríguez-López, S. Montejó-Sánchez, R. D. Souza, O. L. A. López, and H. Alves, "Energy-efficient wake-up signalling for machine-type devices based on traffic-aware long short-term memory prediction," *IEEE Internet Things J.*, vol. 9, no. 21, pp. 21620–21631, Nov. 2022.
- [38] S. Leng and A. Yener, "Learning to transmit fresh information in energy harvesting networks," *IEEE Trans. Green Commun. Netw.*, vol. 6, no. 4, pp. 2032–2042, Dec. 2022.
- [39] X. Ye, Y. Yu, and L. Fu, "Multi-channel opportunistic access for heterogeneous networks based on deep reinforcement learning," *IEEE Trans. Wireless Commun.*, vol. 21, no. 2, pp. 794–807, Feb. 2022.
- [40] J. Baek and G. Kaddoum, "Online partial offloading and task scheduling in SDN-fog networks with deep recurrent reinforcement learning," *IEEE Internet Things J.*, vol. 9, no. 13, pp. 11578–11589, Jul. 2022.
- [41] M. Tang and V. W. Wong, "Deep reinforcement learning for task offloading in mobile edge computing systems," *IEEE Trans. Mobile Comput.*, vol. 21, no. 6, pp. 1985–1997, Jun. 2020.
- [42] Y. Azimi, S. Yousefi, H. Kalbkhani, and T. Kunz, "Energy-efficient deep reinforcement learning assisted resource allocation for 5G-RAN slicing," *IEEE Trans. Veh. Technol.*, vol. 71, no. 1, pp. 856–871, Jan. 2022.
- [43] K. Li, W. Ni, and F. Dressler, "LSTM-characterized deep reinforcement learning for continuous flight control and resource allocation in UAV-assisted sensor network," *IEEE Internet Things J.*, vol. 9, no. 6, pp. 4179–4189, Mar. 2022.
- [44] N. Farsad and A. Goldsmith, "Neural network detection of data sequences in communication systems," *IEEE Trans. Signal Process.*, vol. 66, no. 11, pp. 5663–5678, Nov. 2018.
- [45] J. C. G. Diaz, H. Zhao, Y. Zhu, S. Palermo, and S. Hoyos, "Recurrent neural network equalization for wireline communication systems," *IEEE Trans. Circuits Syst. II, Exp. Briefs*, vol. 69, no. 4, pp. 2116–2120, Apr. 2022.
- [46] G. Ru, W. Sun, and L. Gan, "Influence of RNN structural parameters on blind equalization of shortwave channels," in *Proc. 5th Int. Conf. Commun. Inf. Process. (ICCIP)*, Jan. 2019, pp. 300–304.
- [47] S. Lai and M. Li, "Recurrent neural network assisted Equalization for FTN signaling," in *Proc. IEEE Int. Conf. Commun. (ICC)*, Dublin, Ireland, Jun. 2020, pp. 1–6.
- [48] S. Zheng, Y. Liu, and P. H. Siegel, "PR-NN: RNN-based detection for coded partial-response channels," *IEEE J. Sel. Areas Commun.*, vol. 39, no. 7, pp. 1967–1982, Jul. 2021.
- [49] H. Kim, Y. Jiang, R. Rana, S. Kannan, S. Oh, and P. Viswanath. "Communication algorithms via deep learning." May 2018. [Online]. Available: <http://arxiv.org/abs/1805.09317>
- [50] C. Luo, J. Ji, Q. Wang, X. Chen, and P. Li, "Channel state information prediction for 5G wireless communications: A deep learning approach," *IEEE Trans. Netw. Sci. Eng.*, vol. 7, no. 1, pp. 227–236, Jan.–Mar. 2018.
- [51] T. Wang, C.-K. Wen, S. Jin, and G. Y. Li, "Deep learning-based CSI feedback approach for time-varying massive MIMO channels," *IEEE Wireless Commun. Lett.*, vol. 8, no. 2, pp. 416–419, Apr. 2019.
- [52] H. Wang, Y. Wu, G. Min, and W. Miao, "A graph neural network-based digital twin for network slicing management," *IEEE Trans. Ind. Informat.*, vol. 18, no. 2, pp. 1367–1376, Feb. 2022.
- [53] Y. Shen, Y. Shi, J. Zhang, and K. B. Letaief, "Graph neural networks for scalable radio resource management: Architecture design and theoretical analysis," *IEEE J. Sel. Areas Commun.*, vol. 39, no. 1, pp. 101–115, Jan. 2021.
- [54] Y. Shen, J. Zhang, and K. B. Letaief, "How neural architectures affect deep learning for communication networks?" in *Proc. IEEE ICC*, Mar. 2022, pp. 1–8.
- [55] Y. Shen, J. Zhang, S. H. Song, and K. B. Letaief, "Graph neural networks for wireless communications: From theory to practice," *IEEE Trans. Wireless Commun.*, vol. 22, no. 5, pp. 3554–3569, May 2023.
- [56] T. Chen, X. Zhang, M. You, G. Zheng, and S. Lambotharan, "A GNN-based supervised learning framework for resource allocation in wireless IoT networks," *IEEE Internet Things J.*, vol. 9, no. 3, pp. 1712–1724, Feb. 2022.
- [57] J. Guo and C. Yang, "Learning power allocation for multi-cell-multi-user systems with heterogeneous graph neural networks," *IEEE Trans. Wireless Commun.*, vol. 21, no. 2, pp. 884–897, Feb. 2022.
- [58] J. Guo and C. Yang, "Learning power control for cellular systems with heterogeneous graph neural network," in *Proc. IEEE Wireless Commun. Netw. Conf. (WCNC)*, Nanjing, China, Mar. 2021, pp. 1–6.
- [59] X. Zhang, Z. Zhang, and L. Yang, "Learning-based resource allocation in heterogeneous ultradense network," *IEEE Internet Things J.*, vol. 9, no. 20, pp. 20229–20242, Oct. 2022.
- [60] Z. Wang, M. Eisen, and A. Ribeiro, "Unsupervised learning for asynchronous resource allocation in ad-hoc wireless networks," in *Proc. IEEE Int. Conf. Acoust. Speech Signal Process. (ICASSP)*, Toronto, ON, Canada, Jun. 2021, pp. 8143–8147.
- [61] I. Nikoloska and O. Simeone, "Fast power control adaptation via meta-learning for random edge graph neural networks," in *Proc. IEEE 22nd Int. Workshop Signal Process. Adv. Wireless Commun. (SPAWC)*, Lucca, Italy, Sep. 2021, pp. 146–150.
- [62] M. Eisen and A. Ribeiro, "Optimal wireless resource allocation with random edge graph neural networks," *IEEE Trans. Signal Process.*, vol. 68, pp. 2977–2991, 2020.
- [63] Z. Zhao, G. Verma, C. Rao, A. Swami, and S. Segarra, "Distributed scheduling using graph neural networks," in *Proc. IEEE Int. Conf. Acoust. Speech Signal Process. (ICASSP)*, Toronto, ON, Canada, Jun. 2021, pp. 4720–4724.
- [64] S. Zhang, B. Yin, W. Zhang, and Y. Cheng, "Topology aware deep learning for wireless network optimization," *IEEE Trans. Wireless Commun.*, vol. 21, no. 11, pp. 9791–9805, Nov. 2022.
- [65] Y. Xie et al., "Virtualized network function forwarding graph placing in SDN and NFV-enabled IoT networks: A graph neural network assisted deep reinforcement learning method," *IEEE Trans. Netw. Services Manag.*, vol. 19, no. 1, pp. 524–537, Mar. 2022.
- [66] P. Zhang, C. Wang, N. Kumar, W. Zhang, and L. Liu, "Dynamic virtual network embedding algorithm based on graph convolution neural network and reinforcement learning," *IEEE Internet Things J.*, vol. 9, no. 12, pp. 9389–9398, Jun. 2022.

- [67] T. Dong et al., "Intelligent joint network slicing and routing via GCN-powered multi-task deep reinforcement learning," *IEEE Trans. Cogn. Commun. Netw.*, vol. 8, no. 2, pp. 1269–1286, Jun. 2022.
- [68] B. Zhao, J. Guo, and C. Yang, "Learning precoding policy: CNN or GNN?" in *Proc. IEEE Wireless Commun. Netw. Conf. (WCNC)*, Austin, TX, USA, Apr. 2022, pp. 1027–1032.
- [69] T. Jiang, H. V. Cheng, and W. Yu, "Learning to reflect and to beamform for intelligent reflecting surface with implicit channel estimation," *IEEE J. Sel. Areas Commun.*, vol. 39, no. 7, pp. 1931–1945, Jul. 2021.
- [70] T. Xu, X. Tan, Z. Zhang, X. You, and C. Zhang, "MIMO detection based on graph neural network with belief propagation," in *Proc. Int. Conf. Wireless Commun. Signal Process. (WCSP)*, Hangzhou, China, Jun. 2023, pp. 1095–1100.
- [71] A. Kosasih, V. Onasis, V. Miloslavskaya, W. Hardjawana, V. Andrean, and B. Vucetic, "Graph neural network aided MU-MIMO detectors," *IEEE J. Sel. Areas Commun.*, vol. 40, no. 9, pp. 2540–2555, Sep. 2022.
- [72] X. Zhou, J. Zhang, C.-K. Wen, S. Jin, and S. Han, "Graph neural network-enhanced expectation propagation algorithm for MIMO turbo receivers," *IEEE Trans. Signal Process.*, vol. 71, pp. 3458–3473, 2023.
- [73] X. Zhang, S. Zhang, L. Xiao, S. Li, and T. Jiang, "Graph neural network assisted efficient signal detection for OTFS systems," *IEEE Commun. Lett.*, vol. 27, no. 8, pp. 2058–2062, Aug. 2023.
- [74] C.-K. Wen, W.-T. Shih, and S. Jin, "Deep learning for massive MIMO CSI feedback," *IEEE Wireless Commun. Lett.*, vol. 7, no. 5, pp. 748–751, Oct. 2018.
- [75] M. B. Mashhadi, Q. Yang, and D. Gündüz, "CNN-based analog CSI feedback in FDD MIMO-OFDM systems," in *Proc. IEEE Int. Conf. Acoust. Speech Signal Process. (ICASSP)*, Barcelona, Spain, May 2020, pp. 8579–8583.
- [76] P. Dong, H. Zhang, G. Y. Li, I. S. Gaspar, and N. NaderiAlizadeh, "Deep CNN-based channel estimation for mmWave massive MIMO systems," *IEEE J. Sel. Topics Signal Process.*, vol. 13, no. 5, pp. 989–1000, Sep. 2019.
- [77] Y. Chen and C. Han, "Deep CNN-based spherical-wave channel estimation for terahertz ultra-massive MIMO systems," in *Proc. IEEE Global Commun. Conf. (GLOBECOM)*, Taipei, China, Dec. 2020, pp. 1–6.
- [78] S. Liu and X. Huang, "Sparsity-aware channel estimation for mmWave massive MIMO: A deep CNN-based approach," *China Commun.*, vol. 18, no. 6, pp. 162–171, Jun. 2021.
- [79] A. M. Elbir, "CNN-based precoder and combiner design in mmWave MIMO systems," *IEEE Commun. Lett.*, vol. 23, no. 7, pp. 1240–1243, Jul. 2019.
- [80] A. M. Elbir and A. K. Papazafeiropoulos, "Hybrid precoding for multiuser millimeter wave massive MIMO systems: A deep learning approach," *IEEE Trans. Veh. Technol.*, vol. 69, no. 1, pp. 552–563, Jan. 2020.
- [81] H. Jiang, Y. Lu, X. Li, B. Wang, Y. Zhou, and L. Dai, "Attention-based hybrid precoding for mmWave MIMO systems," in *Proc. IEEE Inf. Theory Workshop (ITW)*, Kanazawa, Japan, Oct. 2021, pp. 1–6.
- [82] X. Bao, W. Feng, J. Zheng, and J. Li, "Deep CNN and equivalent channel based hybrid precoding for mmWave massive MIMO systems," *IEEE Access*, vol. 8, pp. 19327–19335, 2020.
- [83] Y. Huang et al., "A GNN-enabled multipath routing algorithm for spatial-temporal varying LEO satellite networks," *IEEE Trans. Veh. Technol.*, vol. 74, no. 4, pp. 5454–5468, Apr. 2024.
- [84] R. Zhu, W. Zhang, P. Wang, J. Chen, J. Wang, and S. Yu, "Energy-efficient graph reinforced vNFC deployment in elastic optical inter-DC networks," *IEEE Trans. Netw. Sci. Eng.*, vol. 11, no. 28, pp. 1591–1604, Mar./Apr. 2024.
- [85] C. Sun, J. Wu, and C. Yang, "Improving learning efficiency for wireless resource allocation with symmetric prior," *IEEE Wireless Commun.*, vol. 29, no. 2, pp. 162–168, Apr. 2022.
- [86] Y. Shen, Y. Shi, J. Zhang, and K. B. Letaief, "A graph neural network approach for scalable wireless power control," in *Proc. IEEE Globecom Workshops (GC Wkshps)*, Dec. 2019, pp. 1–6.
- [87] X. Wang, Q. Qiu, and N. Cheng, "Reliable projection based unsupervised learning for semi-definite QCQP with application of beamforming optimization," 2024, [arXiv:2407.03668](https://arxiv.org/abs/2407.03668).
- [88] Y. Li, S. Han, and C. Yang, "Constrained learning for multicell power control," in *Proc. IEEE 93rd Veh. Technol. Conf. (VTC-Spring)*, Helsinki, Finland, Apr. 2021, pp. 1–5.
- [89] Y. Li, S. Han, and C. Yang, "Multicell power control under rate constraints with deep learning," *IEEE Trans. Wireless Commun.*, vol. 20, no. 12, pp. 7813–7825, Dec. 2021.
- [90] J. Guo and C. Yang, "Learning power allocation for cellular systems with data rate-based deep neural network," in *Proc. IEEE Wireless Commun. Netw. Conf. (WCNC)*, Austin, TX, USA, Apr. 2022, pp. 1033–1038.
- [91] D. Liu, J. Zhao, C. Yang, and L. Hanzo, "Accelerating deep reinforcement learning with the aid of partial model: Energy-efficient predictive video streaming," *IEEE Trans. Wireless Commun.*, vol. 20, no. 6, pp. 3734–3748, Jun. 2021.
- [92] Y. Zou, Z. Wang, X. Chen, H. Zhou, and Y. Zhou, "Knowledge-guided learning for transceiver design in over-the-air federated learning," *IEEE Trans. Wireless Commun.*, vol. 22, no. 1, pp. 270–285, Jan. 2023.
- [93] W. Xia, G. Zheng, Y. Zhu, J. Zhang, J. Wang, and A. P. Petropulu, "A deep learning framework for optimization of MISO downlink beamforming," *IEEE Trans. Commun.*, vol. 68, no. 3, pp. 1866–1880, Mar. 2020.
- [94] J. Zhang, M. You, G. Zheng, I. Krikidis, and L. Zhao, "Model-driven learning for generic MIMO downlink beamforming with uplink channel information," *IEEE Trans. Wireless Commun.*, vol. 21, no. 4, pp. 2368–2382, Apr. 2022.
- [95] Z. Liu, Y. Yang, F. Gao, T. Zhou, and H. Ma, "Deep unsupervised learning for joint antenna selection and hybrid beamforming," *IEEE Trans. Commun.*, vol. 70, no. 3, pp. 1697–1710, Mar. 2022.
- [96] J. Guo, C.-K. Wen, and S. Jin, "Deep learning-based CSI feedback for beamforming in single- and multi-cell massive MIMO systems," *IEEE J. Sel. Areas Commun.*, vol. 39, no. 7, pp. 1872–1884, Jul. 2021.
- [97] A. Chowdhury, G. Verma, C. Rao, A. Swami, and S. Segarra, "Efficient power allocation using graph neural networks and deep algorithm unfolding," in *Proc. IEEE Int. Conf. Acoust. Speech Signal Process. (ICASSP)*, Toronto, ON, Canada, Jun. 2021, pp. 4725–4729.
- [98] A. Chowdhury, G. Verma, C. Rao, A. Swami, and S. Segarra, "Unfolding WMMSE using graph neural networks for efficient power allocation," *IEEE Trans. Wireless Commun.*, vol. 20, no. 9, pp. 6004–6017, Sep. 2021.
- [99] B. Li, G. Verma, and S. Segarra, "Graph-based algorithm unfolding for energy-aware power allocation in wireless networks," *IEEE Trans. Wireless Commun.*, vol. 22, no. 2, pp. 1359–1373, Sep. 2022.
- [100] H. Wang et al., "Decentralized statistical inference with unrolled graph neural networks," in *Proc. IEEE Conf. Decis. Control (CDC)*, Austin, TX, USA, Dec. 2021, pp. 2634–2640.
- [101] H. Kim, J. Lee, W. Shin, and H. V. Poor, "Shallow reinforcement learning for energy harvesting communications with imperfect channel knowledge," *IEEE J. Sel. Topics Signal Process.*, vol. 15, no. 5, pp. 1258–1271, Aug. 2021.
- [102] H. Kim, T. Cho, J. Lee, W. Shin, and H. V. Poor, "Optimized shallow neural networks for sum-rate maximization in energy harvesting downlink multiuser NOMA systems," *IEEE J. Sel. Areas Commun.*, vol. 39, no. 4, pp. 982–997, Apr. 2021.
- [103] Q. Shi, M. Razaviyayn, Z.-Q. Luo, and C. He, "An iteratively weighted MMSE approach to distributed sum-utility maximization for a MIMO interfering broadcast channel," *IEEE Trans. Signal Process.*, vol. 59, no. 9, pp. 4331–4340, Sep. 2011.
- [104] Q. Hu, Y. Liu, Y. Cai, G. Yu, and Z. Ding, "Joint deep reinforcement learning and unfolding: Beam selection and precoding for mmWave multiuser MIMO with lens arrays," *IEEE J. Sel. Areas Commun.*, vol. 39, no. 8, pp. 2289–2304, Aug. 2021.
- [105] Y. Liu, Q. Hu, Y. Cai, G. Yu, and G. Y. Li, "Deep-unfolding beamforming for intelligent reflecting surface assisted full-duplex systems," *IEEE Trans. Wireless Commun.*, vol. 21, no. 7, pp. 4784–4800, Jul. 2022.
- [106] L. Pellaco, M. Bengtsson, and J. Jalden, "Matrix-inverse-free deep unfolding of the weighted MMSE beamforming algorithm," *IEEE Open J. Commun. Soc.*, vol. 3, pp. 65–81, 2022.
- [107] L. Pellaco, M. Bengtsson, and J. Jalden, "Deep weighted MMSE downlink beamforming," in *Proc. IEEE Int. Conf. Acoust. Speech Signal Process. (ICASSP)*, Toronto, ON, Canada, Jun. 2021, pp. 4915–4919.
- [108] L. Schynol and M. Pesavento, "Coordinated sum-rate maximization in multicell MU-MIMO with deep unrolling," Feb. 2022, [arXiv:2202.10371](https://arxiv.org/abs/2202.10371).
- [109] C.-H. Lin, Y.-T. Lee, W.-H. Chung, S.-C. Lin, and T.-S. Lee, "Unsupervised ResNet-inspired beamforming design using deep unfolding technique," in *Proc. IEEE Global Commun. Conf. (GLOBECOM)*, Taipei, China, Dec. 2020, pp. 1–7.
- [110] G. Zhang, X. Fu, Q. Hu, Y. Cai, and G. Yu, "Hybrid precoding design based on dual-layer deep-unfolding neural network," in *Proc. IEEE 32nd Annu. Int. Symp. Pers. Indoor Mobile Radio Commun. (PIMRC)*, Helsinki, Finland, Sep. 2021, pp. 678–683.

- [111] M.-M. Zhao, A. Liu, Y. Wan, and R. Zhang, "Two-timescale beamforming optimization for intelligent reflecting surface aided multiuser communication with QoS constraints," *IEEE Trans. Wireless Commun.*, vol. 20, no. 9, pp. 6179–6194, Sep. 2021.
- [112] A. Liu, R. Yang, T. Q. S. Quek, and M.-J. Zhao, "Two-stage stochastic optimization via primal–dual decomposition and deep unrolling," *IEEE Trans. Signal Process.*, vol. 69, pp. 3000–3015, 2021.
- [113] P. Wang, J. Fang, Z. Wu, and H. Li, "Two-timescale beamforming for IRS-assisted millimeter wave systems: A deep unrolling-based stochastic optimization approach," in *Proc. IEEE 12th Sensor Array Multichannel Signal Process. Workshop (SAM)*, Trondheim, Norway, Jun. 2022, pp. 191–195.
- [114] A. Balatsoukas-Stimming, O. Castañeda, S. Jacobsson, G. Durisi, and C. Studer, "Neural-network optimized 1-bit precoding for massive MU-MIMO," in *Proc. IEEE 20th Int. Workshop Signal Process. Adv. Wireless Commun. (SPAWC)*, Cannes, France, Jul. 2019, pp. 1–5.
- [115] S. Takabe and T. Wadayama, "Deep unfolded multicast beamforming," in *Proc. IEEE Global Commun. Conf. (GLOBECOM)*, Taipei, China, Dec. 2020, pp. 1–6.
- [116] Q. Hu, Y. Cai, Q. Shi, K. Xu, G. Yu, and Z. Ding, "Iterative algorithm induced deep-unfolding neural networks: Precoding design for multiuser MIMO systems," *IEEE Trans. Wireless Commun.*, vol. 20, no. 2, pp. 1394–1410, Feb. 2021.
- [117] N. Samuel, T. Diskin, and A. Wiesel, "Learning to detect," *IEEE Trans. Signal Process.*, vol. 67, no. 10, pp. 2554–2564, May 2019.
- [118] S. Takabe, M. Imanishi, T. Wadayama, R. Hayakawa, and K. Hayashi, "Trainable projected gradient detector for massive overloaded MIMO channels: Data-driven tuning approach," *IEEE Access*, vol. 7, pp. 93326–93338, 2019.
- [119] S. Takabe, M. Imanishi, T. Wadayama, and K. Hayashi, "Deep learning-aided projected gradient detector for massive overloaded MIMO channels," in *Proc. IEEE Int. Conf. Commun. (ICC)*, Shanghai, China, May 2019, pp. 1–6.
- [120] F. Meng, S. Liu, Y. Huang, and Z. Lu, "Learnable model-driven performance prediction and optimization for imperfect MIMO system: Framework and application," Jun. 2022, [arxiv:abs/2206.15072](https://arxiv.org/abs/2206.15072).
- [121] J. Liao, J. Zhao, F. Gao, and G. Y. Li, "A model-driven deep learning method for massive MIMO detection," *IEEE Commun. Lett.*, vol. 24, no. 8, pp. 1724–1728, Aug. 2020.
- [122] C. Liu, J. Thompson, and T. Arslan, "A deep unfolding network for massive multi-user MIMO-OFDM detection," in *Proc. IEEE Wireless Commun. Netw. Conf. (WCNC)*, Austin, TX, USA, Apr. 2022, pp. 2405–2410.
- [123] M.-W. Un, M. Shao, W.-K. Ma, and P. C. Ching, "Deep MIMO detection using ADMM unfolding," in *Proc. IEEE Data Sci. Workshop (DSW)*, Minneapolis, MN, USA, Jun. 2019, pp. 333–337.
- [124] M. Khani, M. Alizadeh, J. Hoydis, and P. Fleming, "Adaptive neural signal detection for massive MIMO," *IEEE Trans. Wireless Commun.*, vol. 19, no. 8, pp. 5635–5648, Aug. 2020.
- [125] Q. Hu, F. Gao, H. Zhang, G. Y. Li, and Z. Xu, "Understanding deep MIMO detection," *IEEE Trans. Wireless Commun.*, vol. 22, no. 12, pp. 9626–9639, Dec. 2023.
- [126] X. Tan et al., "Improving massive MIMO message passing detectors with deep neural network," *IEEE Trans. Veh. Technol.*, vol. 69, no. 2, pp. 1267–1280, Feb. 2020.
- [127] X. Liu and Y. Li, "Deep MIMO detection based on belief propagation," in *Proc. IEEE Inf. Theory Workshop (ITW)*, Guangzhou, China, Nov. 2018, pp. 1–5.
- [128] J. Zhang, H. He, X. Yang, C.-K. Wen, S. Jin, and X. Ma, "Model-driven deep learning based turbo-MIMO receiver," in *Proc. IEEE 21st Int. Workshop Signal Process. Adv. Wireless Commun. (SPAWC)*, May 2020, pp. 1–5.
- [129] H. He, C.-K. Wen, S. Jin, and G. Y. Li, "Model-driven deep learning for MIMO detection," *IEEE Trans. Signal Process.*, vol. 68, pp. 1702–1715, 2020.
- [130] M. Zhang, C. Wen, S. Jin, and F. Zheng, "A model-driven deep learning network for quantized GFDM receiver," *J. Commun. Inf. Netw.*, vol. 4, no. 3, pp. 53–59, Sep. 2019.
- [131] Y. Wei, M.-M. Zhao, M. Hong, M.-J. Zhao, and M. Lei, "Learned conjugate gradient descent network for massive MIMO detection," *IEEE Trans. Signal Process.*, vol. 68, pp. 6336–6349, 2020.
- [132] X. Zhou, J. Zhang, C.-K. Wen, J. Zhang, and S. Jin, "Model-driven deep learning-based signal detector for CP-free MIMO-OFDM systems," in *Proc. IEEE Int. Conf. Commun. Workshops (ICC Workshops)*, Montreal, QC, Canada, Jun. 2021, pp. 1–6.
- [133] X. Zhou, J. Zhang, C.-W. Syu, C.-K. Wen, J. Zhang, and S. Jin, "Model-driven deep learning-based MIMO-OFDM detector: Design, simulation, and experimental results," *IEEE Trans. Commun.*, vol. 70, no. 8, pp. 5193–5207, Aug. 2022.
- [134] M. Borgerding, P. Schniter, and S. Rangan, "AMP-inspired deep networks for sparse linear inverse problems," *IEEE Trans. Signal Process.*, vol. 65, no. 16, pp. 4293–4308, Aug. 2017.
- [135] H. He, C.-K. Wen, S. Jin, and G. Y. Li, "Deep learning-based channel estimation for beamspace mmWave massive MIMO systems," *IEEE Wireless Commun. Lett.*, vol. 7, no. 5, pp. 852–855, Oct. 2018.
- [136] Y. Zhang, Y. Mu, Y. Liu, T. Zhang, and Y. Qian, "Deep learning-based beamspace channel estimation in mmWave massive MIMO systems," *IEEE Wireless Commun. Lett.*, vol. 9, no. 12, pp. 2212–2215, Dec. 2020.
- [137] X. Ma, Z. Gao, F. Gao, and M. Di Renzo, "Model-driven deep learning based channel estimation and feedback for millimeter-wave massive hybrid MIMO systems," *IEEE J. Sel. Areas Commun.*, vol. 39, no. 8, pp. 2388–2406, Aug. 2021.
- [138] Y. Wei, M.-M. Zhao, M. Zhao, M. Lei, and Q. Yu, "An AMP-based network with deep residual learning for mmWave beamspace channel estimation," *IEEE Wireless Commun. Lett.*, vol. 8, no. 4, pp. 1289–1292, Aug. 2019.
- [139] X. Wei, C. Hu, and L. Dai, "Deep learning for beamspace channel estimation in millimeter-wave massive MIMO systems," *IEEE Trans. Commun.*, vol. 69, no. 1, pp. 182–193, Jan. 2021.
- [140] M.-A. Khalighi and J. J. Boutros, "Semi-blind channel estimation using the EM algorithm in iterative MIMO APP detectors," *IEEE Trans. Wireless Commun.*, vol. 5, no. 11, pp. 3165–3173, Nov. 2006.
- [141] H. He, R. Wang, W. Jin, S. Jin, C.-K. Wen, and G. Y. Li, "Beamspace channel estimation for wideband millimeter-wave MIMO: A model-driven unsupervised learning approach," *IEEE Trans. Wireless Commun.*, vol. 22, no. 3, pp. 1808–1822, Mar. 2023.
- [142] Y. Zhang, J. Sun, J. Xue, G. Y. Li, and Z. Xu, "Deep expectation-maximization for joint MIMO channel estimation and signal detection," *IEEE Trans. Signal Process.*, vol. 70, pp. 4483–4497, 2022.
- [143] J. Yang, C.-K. Wen, S. Jin, and F. Gao, "Beamspace channel estimation in mmWave systems via cosparse image reconstruction technique," *IEEE Trans. Commun.*, vol. 66, no. 10, pp. 4767–4782, Oct. 2018.
- [144] K. Kang, Q. Hu, Y. Cai, G. Yu, J. Hoydis, and Y. C. Eldar, "Mixed-timescale deep-unfolding for joint channel estimation and hybrid beamforming," *IEEE J. Sel. Areas Commun.*, vol. 40, no. 9, pp. 2510–2528, Sep. 2022.
- [145] L. Wan, K. Liu, and W. Zhang, "Deep learning-aided off-grid channel estimation for Millimeter wave cellular systems," *IEEE Trans. Wireless Commun.*, vol. 21, no. 5, pp. 3333–3348, May 2022.
- [146] W. Chen, B. Zhang, S. Jin, B. Ai, and Z. Zhong, "Solving sparse linear inverse problems in communication systems: A deep learning approach with adaptive depth," *IEEE J. Sel. Areas Commun.*, vol. 39, no. 1, pp. 4–17, Jan. 2021.
- [147] M. Al-Shoukairi and B. Rao, "Sparse Bayesian learning using approximate message passing," in *Proc. 48th Asilomar Conf. Signals Syst. Comput. (ACSSC)*, Pacific Grove, CA, USA, Nov. 2014, pp. 1957–1961.
- [148] Z. Zhang, Y. Li, C. Huang, Q. Guo, C. Yuen, and Y. L. Guan, "DNN-aided block sparse Bayesian learning for user activity detection and channel estimation in grant-free non-orthogonal random access," *IEEE Trans. Veh. Technol.*, vol. 68, no. 12, pp. 12000–12012, Dec. 2019.
- [149] Y. Qiang, X. Shao, and X. Chen, "A model-driven deep learning algorithm for joint activity detection and channel estimation," *IEEE Commun. Lett.*, vol. 24, no. 11, pp. 2508–2512, Nov. 2020.
- [150] W. Zhu, M. Tao, X. Yuan, and Y. Guan, "Asynchronous massive connectivity with deep-learned approximate message passing," in *Proc. IEEE Int. Conf. Commun. (ICC)*, Nanning, China, Jun. 2020, pp. 1–6.
- [151] W. Zhu, M. Tao, X. Yuan, and Y. Guan, "Deep-learned approximate message passing for asynchronous massive connectivity," *IEEE Trans. Wireless Commun.*, vol. 20, no. 8, pp. 5434–5448, Aug. 2021.
- [152] Y. Shi, H. Choi, Y. Shi, and Y. Zhou, "Algorithm unrolling for massive access via deep neural networks with theoretical guarantee," *IEEE Trans. Wireless Commun.*, vol. 21, no. 2, pp. 945–959, Feb. 2022.
- [153] J.-Y. Xia, S. Li, J.-J. Huang, Z. Yang, I. M. Jaimoukha, and D. Gunduz, "Metalearning-based alternating minimization algorithm for nonconvex optimization," *IEEE Trans. Neural. Netw. Learn. Syst.*, vol. 34, no. 9, pp. 5366–5380, Sep. 2023.
- [154] J. Xia and D. Gunduz, "Meta-learning based beamforming design for MISO downlink," in *Proc. IEEE Int. Symp. Inf. Theory (ISIT)*, Melbourne, VIC, Australia, Jul. 2021, pp. 2954–2959.

- [155] Z. Yang, J.-Y. Xia, J. Luo, S. Zhang, and D. Gunduz, "A learning-aided flexible gradient descent approach to MISO beamforming," *IEEE Wireless Commun. Lett.*, vol. 11, no. 9, pp. 1895–1899, Sep. 2022.
- [156] R. Sun, Y. Wen, N. Cheng, W. Wang, R. Chai, and Y. Hui, "Structural knowledge-driven meta-learning for task offloading in vehicular networks with integrated communications, sensing and computing," *J. Inf. Intell.*, vol. 2, no. 4, pp. 302–324, Feb. 2024.
- [157] X. Zhong, Y. Guo, N. Li, and Y. Chen, "Joint optimization of relay deployment, channel allocation, and relay assignment for UAVs-aided D2D networks," *IEEE ACM Trans. Netw.*, vol. 28, no. 2, pp. 804–817, Apr. 2020.
- [158] J. Guo and C. Yang, "Deep neural networks with data rate model: Learning power allocation efficiently," *IEEE Trans. Commun.*, vol. 71, no. 3, pp. 1447–1461, Mar. 2023.
- [159] X. Gao, S. Jin, C.-K. Wen, and G. Y. Li, "ComNet: Combination of deep learning and expert knowledge in OFDM receivers," *IEEE Commun. Lett.*, vol. 22, no. 12, pp. 2627–2630, Dec. 2018.
- [160] Y. Zhang, J. Chang, Y. Liu, X. Shen, and W. Bai, "Deep learning based underwater acoustic OFDM receiver with joint channel estimation and signal detection," in *Proc. IEEE Int. Conf. Signal Process. Commun. Comput. (ICSPCC)*, Xi'an, China, Oct. 2022, pp. 1–5.
- [161] N. Shlezinger, R. Fu, and Y. C. Eldar, "DeepSIC: Deep soft interference cancellation for multiuser MIMO detection," *IEEE Trans. Wireless Commun.*, vol. 20, no. 2, pp. 1349–1362, Feb. 2021.
- [162] E. Nachmani, E. Marciano, L. Lugosch, W. J. Gross, D. Burshtein, and Y. Be'ery, "Deep learning methods for improved decoding of linear codes," *IEEE J. Sel. Topics Signal Process.*, vol. 12, no. 1, pp. 119–131, Feb. 2018.
- [163] K. Gregor and Y. LeCun, "Learning fast approximations of sparse coding," in *Proc. IEEE Int. Conf. Mach. Learn. (ICML)*, Haifa, Israel, Jun. 2010, pp. 399–406.
- [164] K. Xu, J. Li, M. Zhang, S. S. Du, K. I. Kawarabayashi, and S. Jegelka, "What can neural networks reason about?" in *Proc. Int. Conf. Learn. Rep. (ICLR)*, Apr. 2020, pp. 1–6.
- [165] T. Ding, X. Yuan, and S. C. Liew, "Sparsity learning-based multiuser detection in grant-free massive-device multiple access," *IEEE Trans. Wireless Commun.*, vol. 18, no. 7, pp. 3569–3582, Jul. 2019.
- [166] Z. Chen, F. Sahrabi, and W. Yu, "Sparse activity detection for massive connectivity," *IEEE Trans. Signal Process.*, vol. 66, no. 7, pp. 1890–1904, Apr. 2018.
- [167] L. Liu and W. Yu, "Massive connectivity with massive MIMO—Part I: Device activity detection and channel estimation," *IEEE Trans. Signal Process.*, vol. 66, no. 11, pp. 2933–2946, Jun. 2018.
- [168] M. Ke, Z. Gao, Y. Wu, X. Gao, and R. Schober, "Compressive sensing-based adaptive active user detection and channel estimation: Massive access meets massive MIMO," *IEEE Trans. Signal Process.*, vol. 68, pp. 764–779, 2020.
- [169] T. Jiang, Y. Shi, J. Zhang, and K. B. Letaief, "Joint activity detection and channel estimation for IoT networks: Phase transition and computation-estimation tradeoff," *IEEE Internet Things J.*, vol. 6, no. 4, pp. 6212–6225, Aug. 2019.
- [170] Q. He, T. Q. Quek, Z. Chen, Q. Zhang, and S. Li, "Compressive channel estimation and multi-user detection in C-RAN with low-complexity methods," *IEEE Trans. Wireless Commun.*, vol. 17, no. 6, pp. 3931–3944, Jun. 2018.
- [171] A. Bonnefoy, V. Emiya, L. Ralaivola, and R. Gribonval, "Dynamic screening: Accelerating first-order algorithms for the lasso and group-lasso," *IEEE Trans. Signal Process.*, vol. 63, no. 19, pp. 5121–5132, Oct. 2015.
- [172] Y. Zhang, Q. Guo, Z. Wang, J. Xi, and N. Wu, "Block sparse Bayesian learning based joint user activity detection and channel estimation for grant-free NOMA systems," *IEEE Trans. Veh. Technol.*, vol. 67, no. 10, pp. 9631–9640, Oct. 2018.
- [173] Y. Wang, L. Sun, and A. L. Swindlehurst, "Knowledge-driven signal detector for uplink transmission in IoT networks with unknown channel models," *IEEE Internet Things J.*, vol. 11, no. 5, pp. 25839–25852, Aug. 2024.
- [174] M. Guenach, A. A. Gorji, and A. Bourdoux, "A deep neural architecture for real-time access point scheduling in uplink cell-free massive MIMO," *IEEE Trans. Wireless Commun.*, vol. 21, no. 3, pp. 1529–1541, Mar. 2022.
- [175] S. Tabuchi, I. Makino, and N. Miki, "Combined usage of convex optimization and neural network for resource allocation," in *Proc. Int. Conf. Signal Process. Commun. Syst. (ICSPCS)*, Adelaide, SA, Australia, Dec. 2020, pp. 1–6.
- [176] Z. Xu, J. Guo, and C. Yang, "Predictive resource allocation with interference coordination by deep learning," in *Proc. Int. Conf. Wireless Commun. Signal Process. (WCSP)*, Xi'an, China, Oct. 2019, pp. 1–6.
- [177] W. Wu et al., "Dynamic RAN slicing for service-oriented vehicular networks via constrained learning," *IEEE J. Sel. Areas Commun.*, vol. 39, no. 7, pp. 2076–2089, Jul. 2021.
- [178] W. Wu, P. Yang, W. Zhang, C. Zhou, and X. Shen, "Accuracy-guaranteed collaborative DNN inference in Industrial IoT via deep reinforcement learning," *IEEE Trans. Ind. Informat.*, vol. 17, no. 7, pp. 4988–4998, Jul. 2021.
- [179] A. Omidkar, A. Khalili, H. H. Nguyen, and H. Shafiee, "Reinforcement-learning-based resource allocation for energy-harvesting-aided D2D communications in IoT networks," *IEEE Internet Things J.*, vol. 9, no. 17, pp. 16521–16531, Sep. 2022.
- [180] W. Xing and C. Yang, "Tile-based proactive virtual reality streaming via online hierarchical learning," in *Proc. Asia-Pac. Conf. Commun. (APCC)*, Ho Chi Minh City, Vietnam, Nov. 2019, pp. 232–237.
- [181] D. Li, Y. Xu, M. Zhao, S. Zhang, and J. Zhu, "Knowledge-driven machine learning-based channel estimation in massive MIMO system," in *Proc. IEEE Wireless Commun. Netw. Conf. Workshops (WCNCW)*, Nanjing, China, Mar. 2021, pp. 1–6.
- [182] J. Xia, K. He, W. Xu, S. Zhang, L. Fan, and G. K. Karagiannidis, "A MIMO detector with deep learning in the presence of correlated interference," *IEEE Trans. Veh. Technol.*, vol. 69, no. 4, pp. 4492–4497, Apr. 2020.
- [183] L. Xu, F. Gao, W. Zhang, and S. Ma, "Model aided deep learning based MIMO OFDM receiver with nonlinear power amplifiers," in *Proc. IEEE Wireless Commun. Netw. Conf. (WCNC)*, Nanjing, China, Mar. 2021, pp. 1–6.
- [184] X. Wang, H. Hua, and Y. Xu, "Pilot-assisted channel estimation and signal detection in uplink multi-user MIMO systems with deep learning," *IEEE Access*, vol. 8, pp. 44936–44946, 2020.
- [185] Y. Cui, S. Li, and W. Zhang, "Jointly sparse signal recovery and support recovery via deep learning with applications in MIMO-based grant-free random access," *IEEE J. Sel. Areas Commun.*, vol. 39, no. 3, pp. 788–803, Mar. 2021.
- [186] Y. Zheng et al., "Leveraging domain knowledge for robust deep reinforcement learning in networking," in *Proc. IEEE Conf. Comput. Commun. (INFOCOM)*, Vancouver, BC, Canada, May 2021, pp. 1–10.
- [187] Y. Zheng et al., "Enabling robust DRL-driven networking systems via teacher-student learning," *IEEE J. Sel. Areas Commun.*, vol. 40, no. 1, pp. 376–392, Jan. 2022.
- [188] Y. Li, X. Qin, H. Chen, K. Han, and P. Zhang, "Energy-aware edge association for cluster-based Personalized federated learning," *IEEE Trans. Veh. Technol.*, vol. 71, no. 6, pp. 6756–6761, Jun. 2022.
- [189] D. Liu, C. Sun, C. Yang, and L. Hanzo, "Optimizing wireless systems using unsupervised and reinforced-unsupervised deep learning," *IEEE Netw.*, vol. 34, no. 4, pp. 270–277, Jul. 2020.
- [190] M. Eisen, C. Zhang, L. F. O. Chamon, D. D. Lee, and A. Ribeiro, "Dual domain learning of optimal resource allocations in wireless systems," in *Proc. IEEE Int. Conf. Acoust. Speech Signal Process. (ICASSP)*, Brighton, U.K., May 2019, pp. 4729–4733.
- [191] M. Yin, C. Sun, C. Yang, and S. Han, "Probabilistic constrained optimization for predictive video streaming by deep learning," *IEEE Trans. Commun.*, vol. 71, no. 2, pp. 823–836, Feb. 2023.
- [192] C. Sun and C. Yang, "Unsupervised deep learning for ultra-reliable and low-latency communications," in *Proc. IEEE Global Commun. Conf. (GLOBECOM)*, Waikoloa, HI, USA, Dec. 2019, pp. 1–6.
- [193] J. Guo, Z. Xu, and C. Yang, "Learning fairly with class-imbalanced data for interference coordination," *IEEE Trans. Veh. Technol.*, vol. 70, no. 7, pp. 7176–7181, Jul. 2021.
- [194] H. Sun, W. Pu, X. Fu, T.-H. Chang, and M. Hong, "Learning to continuously optimize wireless resource in a dynamic environment: A bilevel optimization perspective," *IEEE Trans. Signal Process.*, vol. 70, pp. 1900–1917, 2022.
- [195] Z. Gu et al., "Knowledge-assisted deep reinforcement learning in 5G scheduler design: From theoretical framework to implementation," *IEEE J. Sel. Areas Commun.*, vol. 39, no. 7, pp. 2014–2028, Jul. 2021.
- [196] Y. Yu, J. Liu, and J. Fang, "Online microservice orchestration for IoT via multiobjective deep reinforcement learning," *IEEE Internet Things J.*, vol. 9, no. 18, pp. 17513–17525, Sep. 2022.
- [197] D. Liu, J. Cui, J. Zhang, C. Yang, and L. Hanzo, "Deep reinforcement learning aided packet-routing for aeronautical ad-hoc networks formed by passenger planes," *IEEE Trans. Veh. Technol.*, vol. 70, no. 5, pp. 5166–5171, May 2021.
- [198] S. Yin and F. R. Yu, "Resource allocation and trajectory design in UAV-aided cellular networks based on multiagent reinforcement learning," *IEEE Internet Things J.*, vol. 9, no. 4, pp. 2933–2943, Feb. 2022.
- [199] J. Guo, X. Yang, C.-K. Wen, S. Jin, and G. Y. Li, "DL-based CSI feedback and cooperative recovery in massive MIMO," Mar. 2020, *arXiv:2003.03303*.

- [200] Y.-C. Lin, Z. Liu, T.-S. Lee, and Z. Ding, "Deep learning phase compression for MIMO CSI feedback by exploiting FDD channel reciprocity," *IEEE Wireless Commun. Lett.*, vol. 10, no. 10, pp. 2200–2204, Oct. 2021.
- [201] N. Ye, X. Li, H. Yu, A. Wang, W. Liu, and X. Hou, "Deep learning aided grant-free NOMA toward reliable low-latency access in tactile internet of things," *IEEE Trans. Ind. Informat.*, vol. 15, no. 5, pp. 2995–3005, May 2019.
- [202] D. Liu, J. Zhao, and C. Yang, "Energy-saving predictive video streaming with deep reinforcement learning," in *Proc. IEEE Global Commun. Conf. (GLOBECOM)*, Waikoloa, HI, USA, Dec. 2019, pp. 1–6.
- [203] Z. Liu, L. Zhang, and Z. Ding, "Exploiting bi-directional channel reciprocity in deep learning for low rate massive MIMO CSI feedback," *IEEE Wireless Commun. Lett.*, vol. 8, no. 3, pp. 889–892, Jun. 2019.
- [204] J. Guo, C.-K. Wen, S. Jin, and G. Y. Li, "Convolutional neural network-based multiple-rate compressive sensing for massive MIMO CSI feedback: Design, simulation, and analysis," *IEEE Trans. Wireless Commun.*, vol. 19, no. 4, pp. 2827–2840, Apr. 2020.
- [205] Z. Lu, J. Wang, and J. Song, "Multi-resolution CSI feedback with deep learning in massive MIMO system," in *Proc. IEEE Int. Conf. Commun. (ICC)*, Dublin, Ireland, Jul. 2020, pp. 1–6.
- [206] J. Guo and C. Yang, "Structure of deep neural networks with a priori information in wireless tasks," in *Proc. IEEE Int. Conf. Commun. (ICC)*, Dublin, Ireland, Jun. 2020, pp. 1–6.
- [207] X. Ye, K. Qu, W. Zhuang, and X. Shen, "Accuracy-aware cooperative sensing and computing for connected autonomous vehicles," *IEEE Trans. Mobile Comput.*, vol. 23, no. 9, pp. 8193–8207, Aug. 2024.
- [208] H. Du et al., "The age of generative AI and AI-generated everything," *IEEE Neww.*, vol. 38, no. 6, pp. 501–512, Nov. 2024.
- [209] C. Zhao et al., "Generative AI for secure physical layer communications: A survey," *IEEE Trans. Cogn. Commun. Netw.*, vol. 11, no. 1, pp. 3–26, Feb. 2025.
- [210] C. Zhang et al., "Multi-objective aerial collaborative secure communication optimization via generative diffusion model-enabled deep reinforcement learning," 2024, *arXiv:2407.08914*.
- [211] C. Zhang, S. Yu, Z. Tian, and J. J. Yu, "Generative adversarial networks: A survey on attack and defense perspective," *ACM Comput. Surv.*, vol. 56, no. 4, pp. 1–35, Nov. 2023.
- [212] "OpenAI: ChatGPT." 2024. [Online]. Available: <https://chat.openai.com/chat>
- [213] Y. Wang, C. Yang, S. Lan, L. Zhu, and Y. Zhang, "End-edge-cloud collaborative computing for deep learning: A comprehensive survey," *IEEE Commun. Surveys Tuts.*, vol. 26, no. 4, pp. 2647–2683, 4th Quart., 2024.
- [214] X. Zhang et al., "Beyond the cloud: Edge inference for generative large language models in wireless networks," *IEEE Trans. Wireless Commun.*, vol. 24, no. 1, pp. 643–658, Jan. 2025.
- [215] J. Shao et al., "WirelessLLM: Empowering large language models towards wireless intelligence," *IEEE J. Commun. Inf. Netw.*, vol. 9, no. 2, pp. 99–112, May 2024.
- [216] Y. Huang et al., "Large language models for networking: Applications, enabling techniques, and challenges," *IEEE Neww.*, vol. 39, no. 1, pp. 235–242, Jan. 2025.
- [217] A. Maatouk, F. Ayed, N. Piovesan, A. De Domenico, M. Debbah, and Z.-Q. Luo, "TeleQnA: A benchmark dataset to assess large language models telecommunications knowledge." Oct. 2023. [Online]. Available: <https://arxiv.org/abs/2310.15051>
- [218] D. Wu et al., "NetLLM: Adapting large language models for networking," in *Proc. ACM Special Interest Group Data Commun. (SIGCOMM)*, Sydney, NSW, Australia, Aug. 2024, pp. 1–18.
- [219] "Study on artificial intelligence (AI)/machine learning (ML) for NR air interface," 3GPP, Sophia Antipolis, France, Rep. TR 38.843, Dec. 2023.
- [220] "IEEE 802.11 AIML TIG technical report," 3GPP, Sophia Antipolis, France, Rep. 987r25, Nov. 2023.



Ruijin Sun (Member, IEEE) received the Ph.D. degree from the Beijing University of Posts and Telecommunications, Beijing, China, in 2019. From September 2017 to September 2018, she was a visiting student with the University of Waterloo, Waterloo, ON, Canada. From 2019 to 2021, she was a Joint Postdoctoral Fellow with Peng Cheng Laboratory, Shenzhen, China, and Tsinghua University, Beijing. She is currently an Associate Professor with the School of Telecommunications Engineering and the State Key Laboratory of

Integrated Services Networks, Xidian University, Xi'an, China. Her research interests include knowledge-driven wireless resource allocation.



Nan Cheng (Senior Member, IEEE) received the B.E. and the M.S. degrees in information and telecommunications engineering from Tongji University in 2009 and 2012, respectively, and the Ph.D. degree in electrical and computer engineering from the University of Waterloo in 2016. He worked as a Postdoctoral fellow with the Department of Electrical and Computer Engineering, University of Toronto from 2017 to 2019. He is currently a Professor with the State Key Laboratory of ISN and the School of Telecommunications Engineering, Xidian University, Xi'an, Shaanxi, China. He has published over 90 journal papers in IEEE Transactions and other top journals. His current research focuses on intelligent radio map, B5G/6G, AI-driven future networks, and space-air-ground integrated network. He serves as an Associate Editor for IEEE INTERNET OF THINGS JOURNAL, IEEE TRANSACTIONS ON VEHICULAR TECHNOLOGY, IEEE OPEN JOURNAL OF THE VEHICULAR TECHNOLOGY, and *Peer-to-Peer Networking and Applications*, and serves/served as a guest editor for several journals.



Changle Li (Senior Member, IEEE) received the Ph.D. degree in communication and information system from Xidian University, Xi'an, China, in 2005. He was a Postdoctoral Researcher in Canada and the National Institute of information and Communications Technology, Tokyo, Japan. He had been a Visiting Scholar with the University of Technology Sydney, Ultimo, NSW, Australia, and is currently a Professor with the State Key Laboratory of Integrated Services Networks, Xidian University. His research interests include intelligent transportation systems, vehicular networks, mobile ad hoc networks, and wireless sensor networks.



Wei Quan (Senior Member, IEEE) received the Ph.D. degree in communication and information system from the Beijing University of Posts and Telecommunications, Beijing, China, in 2014. He is currently a Full Professor with the School of Electronic and Information Engineering, Beijing Jiaotong University, Beijing. He has co-authored more than 50 papers in prestigious international journals and conferences, including IEEE JOURNAL ON SELECTED AREAS IN COMMUNICATIONS, *IEEE Communications Magazine*, IEEE WIRELESS COMMUNICATIONS, IEEE NETWORK, IEEE TRANSACTIONS ON VEHICULAR TECHNOLOGY, and IEEE COMMUNICATIONS LETTERS. His research interests focus on reliable transmission in mobile networks, vehicular networks, and Industrial IoT. He is an Associate Editor of the IEEE TRANSACTIONS ON VEHICULAR TECHNOLOGY, *Peer-to-Peer Networking and Applications*, *Journal of Internet Technology*, and IEEE ACCESS. He is a Winner of 2022 IEEE ComSoc Asia-Pacific Outstanding Young Researcher Award and a Principle Investigator (PI) of National Key Research and Development Program of China.



Haibo Zhou (Senior Member, IEEE) received the Ph.D. degree in information and communication engineering from Shanghai Jiao Tong University, Shanghai, China, in 2014. From 2014 to 2017, he was a Postdoctoral Fellow with the Broadband Communications Research Group, Department of Electrical and Computer Engineering, University of Waterloo. He is currently a Full Professor with the School of Electronic Science and Engineering, Nanjing University, Nanjing, China. His research interests include resource management and protocol

design in B5G/6G networks, vehicular ad hoc networks, and space-air-ground integrated networks. He was the recipient of the 2019 IEEE ComSoc Asia-Pacific Outstanding Young Researcher Award, 2023–2024 IEEE ComSoc Distinguished Lecturer, and 2023–2025 IEEE VTS Distinguished Lecturer. He was a Track/Symposium Co-Chair for IEEE/CIC ICC 2019, IEEE VTC-Fall 2020, IEEE VTC-Fall 2021, WCSP 2022, IEEE GLOBECOM 2022, and IEEE ICC 2024. He is currently an Associate Editor of the IEEE TRANSACTIONS ON WIRELESS COMMUNICATIONS, IEEE INTERNET OF THINGS JOURNAL, *IEEE Network Magazine*, and *Journal of Communications and Information Networks*.



Ying Wang (Member, IEEE) received the Ph.D. degree in circuits and systems from the Beijing University of Posts and Telecommunications (BUPT), Beijing, China, in 2003. In 2004, she was invited to work as a Visiting Researcher with the Communications Research Laboratory (renamed NiCT from 2004), Yokosuka, Japan. She was a Research Associate with the University of Hong Kong, Hong Kong, in 2005. She is currently a Professor with BUPT, where she is also the Director of the Radio Resource Management Laboratory,

Wireless Technology Innovation Institute. Her research interests are in the area of the cooperative and cognitive systems, radio resource management, and mobility management in 5G systems. She is active in standardization activities of 3GPP and ITU. She took part in performance evaluation work of the Chinese Evaluation Group, as a Representative of BUPT. She has authored over 100 papers in international journals and conferences proceedings. Her research interests include cooperative and cognitive systems, radio resource management, and mobility management in 5G systems. She was a recipient of first prizes of the Scientific and Technological Progress Award by the China Institute of Communications in 2006 and 2009, respectively, and a second prize of the National Scientific and Technological Progress Award in 2008. She was also selected in the New Star Program of Beijing Science and Technology Committee and the New Century Excellent Talents in University, Ministry of Education, in 2007 and 2009, respectively.

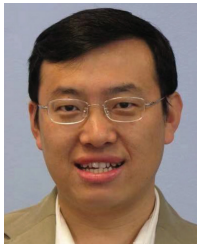

Wei Zhang (Fellow, IEEE) received the Ph.D. degree in electronic engineering from the Chinese University of Hong Kong in 2005. He is currently a Professor with the School of Electrical Engineering and Telecommunications, The University of New South Wales, Sydney, NSW, Australia. He has published more than 200 articles and holds five U.S. patents. His research interests include millimetre wave communications and massive MIMO. He currently serves as an Area Editor for the IEEE TRANSACTIONS ON WIRELESS

COMMUNICATIONS and the Editor-in-Chief of *Journal of Communications and Information Networks*. He is the Vice President of the IEEE Communications Society.



Xuemin (Sherman) Shen (Fellow, IEEE) received the Ph.D. degree in electrical engineering from Rutgers University, New Brunswick, NJ, USA, in 1990. He is currently a University Professor with the Department of Electrical and Computer Engineering, University of Waterloo, Canada. His research interests include network resource management, wireless network security, the Internet of Things, 5G and beyond, and vehicular ad hoc and sensor networks. He is a Registered Professional Engineer of Ontario, Canada, an Engineering Institute of

Canada Fellow, a Canadian Academy of Engineering Fellow, a Royal Society of Canada Fellow, a Chinese Academy of Engineering Foreign Member, and a Distinguished Lecturer of the IEEE Vehicular Technology Society and Communications Society. He received the R.A. Fessenden Award from IEEE, Canada, in 2019, the Award of Merit from the Federation of Chinese Canadian Professionals, ON, Canada, in 2019, the James Evans Avant Garde Award from the IEEE Vehicular Technology Society in 2018, the Joseph LoCicero Award in 2015, and Education Award in 2017 from the IEEE Communications Society, and the Technical Recognition Award from Wireless Communications Technical Committee in 2019 and AHSN Technical Committee in 2013. He has also received the Excellent Graduate Supervision Award from the University of Waterloo in 2006 and the Premier's Research Excellence Award (PREA) from the Province of Ontario, Canada, in 2003. He served as the Technical Program Committee Chair/the Co-Chair for IEEE Globecom'16, IEEE Infocom'14, IEEE VTC'10 Fall, and IEEE Globecom'07, and the Chair for the IEEE Communications Society Technical Committee on Wireless Communications. He is the President Elect of the IEEE Communications Society. He was the Vice President for Technical and Educational Activities, the Vice President for Publications, a Member-at-Large on the Board of Governors, the Chair of the Distinguished Lecturer Selection Committee, and a member of IEEE Fellow Selection Committee of the ComSoc. He served as the Editor-in-Chief for the IEEE INTERNET OF THINGS JOURNAL, IEEE NETWORK, and *IET Communications*.